



**The next generation of compact ultrasonic analog sensors that outperforms many other sensor types in all types of applications.**

The new Virtu™ Analog ultrasonic sensor developed by Hyde Park features sensing ranges from 50.8 mm (2") up to 508 mm (20").

Virtu's dual-mount body style, with its M18 x 1 threaded snout 0.89" long and a 1.49" rectangular body for a total length of only 2.38", and tough VALOX® housing make it not only ideal for many OEM applications but also an unfailing performer for an array of packaging applications, including food and beverage. Available in cable or connector style, Virtu™ is the first sonic compact sensor to offer a dual mounting feature. It operates on 15 to 24 VDC. Virtu™ also has teach-in window capability, and no downtime is required for sensor recalibration when colors, materials, or shapes change.

With protection ratings of 4X and IP67, this CE certified sensor is resistant to dust, 100% humidity, most acids and bases, and high pressure washdowns that often leave water buildup on the sensing face. This sleek sensor is virtually impervious to the effects of splashing food, caustic cleaning solutions, and changing light conditions or colors. Shielding and filtering

make the fully encapsulated sensor resistant to radiated or conducted energy.

### Operation

The Virtu™ Analog series is a self-contained, pulse-echo, analog sensing device that both transmits and receives sonic energy within a 508 mm (20") maximum sensing range. Operating on 15 to 24 VDC, and employing the latest piezoelectric and microprocessor technology, Virtu™ sensors detect only those designated objects within a set "window" and ignore all surrounding sonic interference.

Prior to operation, a simple and easy "teach" function is used to set the sensing window limits through either a remote or inline cable push-button. A near and far limit for a desired sensing window can be set anywhere within the sensing range and may be set to either encompass the full sensing range or be as small as 6 mm (0.25").

The sensor is equipped with three LED's to show the sensing status. The amber LED is off when an object is within the sensing window. The amber LED is on when an object is being sensed within the range of the sensor. The orange LED indicates the relative value of the analog output and varies in intensity according to the output. The higher the current or voltage output, the brighter the orange LED.

## VIRTU™ Analog Ultrasonic Sensors

- *Auto Slope, direct and inverse output versions*
- *Sensing range of 50.8 mm (2") up to 508 mm (20")*
- *Dual-mount flat-profile and 18 mm barrel body styles*
- *Rugged duty design for harsh environments*
- *Simple remote push-button accessory available for teaching of sensing limits*
- *NEMA 4X (indoor use only), IP67*
- *CE certified*

## Setting the Window Limits

Before operating the sensor, you should teach the sensor the sensing window. The sensing window is the distance between the near and far limits. To teach the limits, press and hold the push-button. The amber LED fast flashes and then after holding the push-button for three seconds, the green LED slowly flashes indicating the sensor is in teach mode. Release the push-button, and the green LED continues slowly flashing indicating the sensor is waiting for the first limit. Place a target at the distance corresponding to the analog minimum (0 V or 4 mA), then press and release the push-button. While the push-button is pressed with a target present, the amber LED turns on indicating a valid echo is being detected. After the first limit is taught successfully, the amber LED slowly flashes indicating the sensor is waiting for the second limit. Place a target at the distance corresponding to the analog maximum (10 V or 20 mA), then press and release the push-button. While the push-button is pressed with a target present, the amber LED turns on indicating a valid echo is being detected. After the second limit is taught, the two limits are saved in non-volatile memory. The green LED fast flashes for 3 seconds to indicate the limits were successfully saved.

While setting either limit, if no echo is detected, the green and amber LED fast flashes indicating no object is detected. After 5 seconds, the sensor resumes operation with the old limits. If either limit is not set in 30 seconds, a limit timeout occurs, the LED flashes green and amber for 3 seconds indicating the error. The sensor then resumes operating with the old limits.

If not using an optional push-button, the process is similar. The white teach wire (pin 2) can be grounded to the blue DC return wire (pin 3) to simulate the pushing of the button. All LED indications and the teach sequence is identical to the previously detailed process.

## How Does It Work?

During teach and operation, the Virtu™ sensor continually and accurately measures the elapsed time from the first pulse echo received after each

pulse transmission. The transmitted pulse begins a time clock to register the elapsed time of the first received pulse echo. Given the elapsed time, the sensor software calculates the distance traveled out to the object or surface and back to the sensor, using the formula  $D=TVs/2$ , where: D = distance from the sensor to the object; T = elapsed time between the pulse transmission and its first received echo; Vs = the velocity of sound, approximately 335 meters (1100 feet) per second.

During operation, the calculated distance (D) between the sensor and the object is compared to the distances between the sensor and the analog span limits. These limits are shown in the illustration as Dwi and Dwo. If D is at or within the analog span limits, an output value for D, relative to the analog span limits is generated.

## Electrical Wiring

The sensor cable must be run in conduit free of any AC power or control wires.

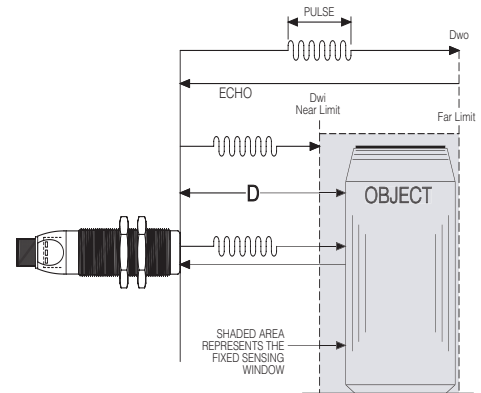

### Micro Connector Style 0-10 V

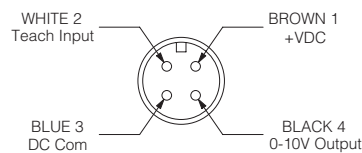

### 4-20 mA

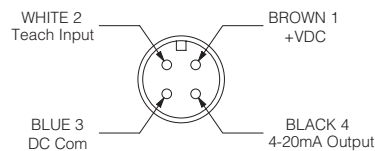

### Cable Style Model

#### 0-10V

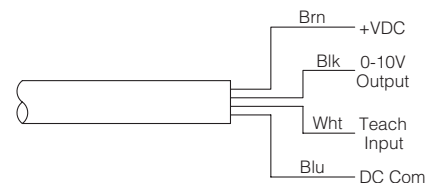

#### 4-20 mA

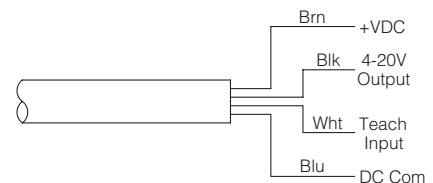

## Output Style

### 0-10 V Output

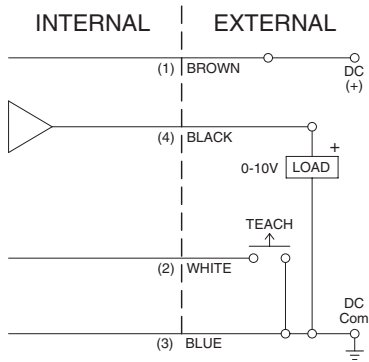

## Output Type

### Direct Slope

The sensing window is determined by a teachable near and far limit, which can be set anywhere between the deadband (50.8 mm / 2.0 in) and the maximum sensing range (508 mm / 20 in.). The sensing window is taught using either an inline pushbutton switch or by grounding the teach wire.

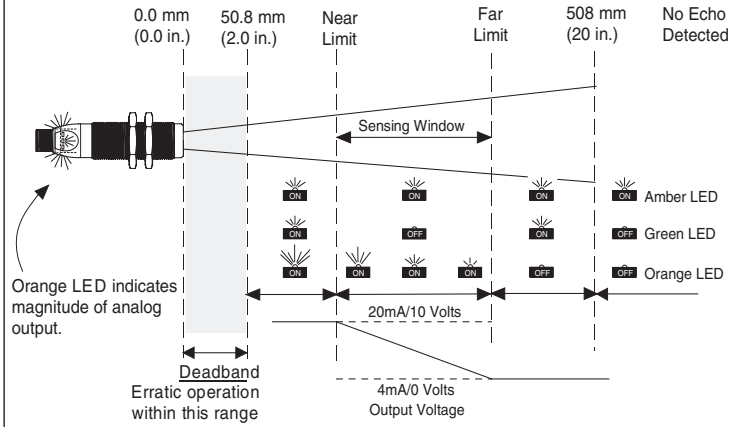

### 4-20 mA Output

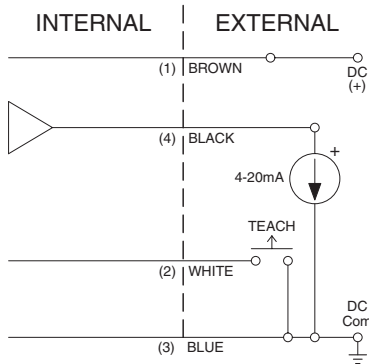

### Inverse Slope

The sensing window is determined by a teachable near and far limit, which can be set anywhere between the deadband (50.8 mm / 2.0 in) and the maximum sensing range (508 mm / 20 in.). The sensing window is taught using either an inline pushbutton switch or by grounding the teach wire.

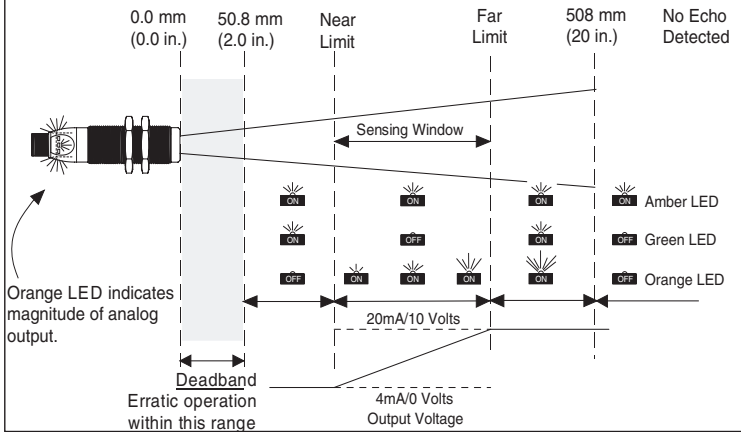

## Beam Plots

The following plots, developed from data collected at 20°C and zero air flow, define the boundaries and shape of the sonic beam for the Virtu series sensors.

The boundaries were established using a 10 cm x 10 cm (3.94" x 3.94") "target" positioned parallel to the sensor face. The plot for each sensor series is valid for targets equal to or larger than 10 cm x 10 cm. Beam boundaries are determined by moving the large flat target into the beam while the plane of the target is held perpendicular to the beam axis.

In each sensor series, the plot extends from the end of the "deadband" on the left to the end of the sensing range on the right. The sensor is illustrated in the middle left margin.

These and other plots are available from the SCC upon request.

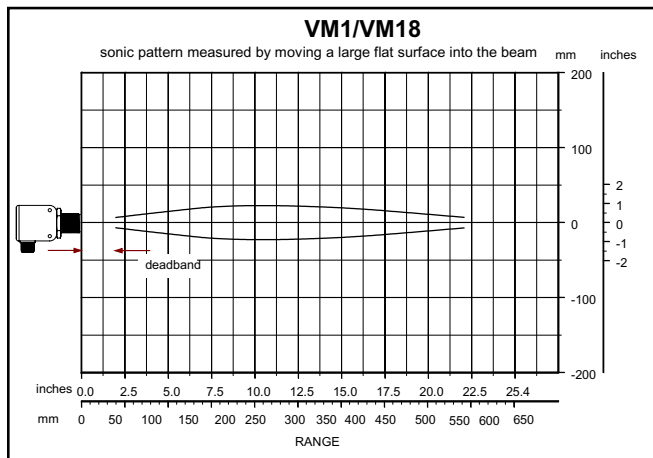

## Dimensions

### Quick Disconnect Style

(VALOX® Plastic) VM1-XXX-X

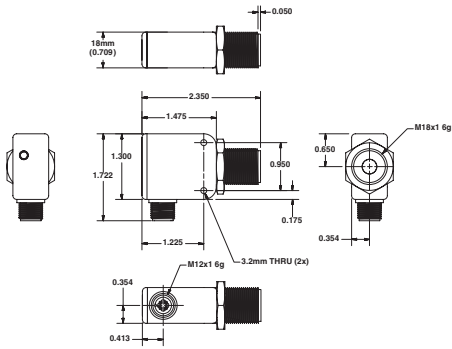

### Cable Style

(VALOX® Plastic) VM1-XXX-X

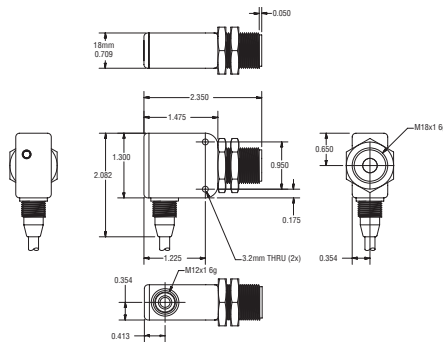

### Quick Disconnect Style

(VALOX® Plastic) VM18-XXX-X

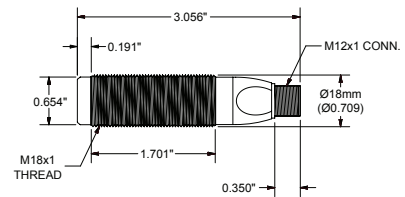

### Cable Style

(VALOX® Plastic) VM18-XXX-X

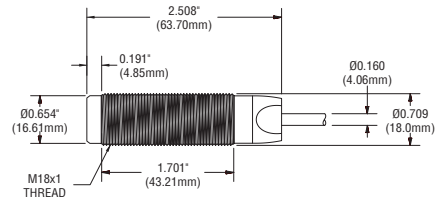

## Accessories

**AC130** Straight, M12 micro, 4-conductor, connector/cable assembly, 5 m (16')

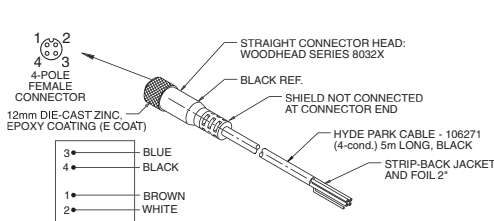

**PB100** In-line accessory push-button for teaching window limits (for Virtu™ series sensors).

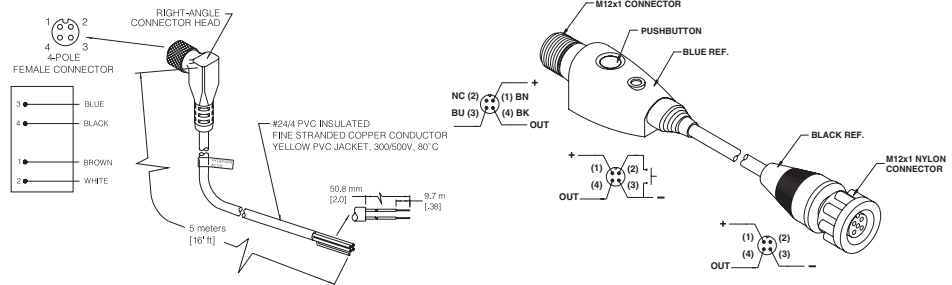

**AC132** Right-angle, M12 micro, 4-conductor, connector/cable assembly, 5 m (16') (for flat-profile connector-style sensors)

## General Specifications

**Sensing:** [ $T_a=20^\circ\text{C}$  (68°F)] -Large Flat Target  
Range: 50.8 mm (2.0 in.) to 508 mm (20 in.)  
Maximum plane-reflector angle:  $\pm 5^\circ$   
Sonic Cone Angle: See beam plot

Window-edge accuracy:  $\pm 1.27$  mm (0.050 in.) @ constant temperature  
Minimum object size Rod: 2.5 mm (0.098in) at 254.0 mm (10.0") range, 0°tilt  
Factory Set sensing window 50.8 mm (2.0 in.) to 508 mm (20 in.)  
Temperature Compensation Temperature Compensated

### Power Requirements:

Supply Voltage: +15 to 24 VDC ( $\pm 10\%$ ) @ 40 mA max (including output load)  
Protection: ESD and reverse-polarity

### Analog Output:

#### CA Models:

Output Range: 4-20 milliamps  
Load resistance: 10 to 350 ohms  
Protection: ESD and short circuit

#### VA Models

Output Range: 0-10 volts  
Load resistance: 2K ohms minimum  
Protection: ESD and short circuit

### Pushbutton Input:

Active voltage level: < 1.0 volt  
Inactive voltage level: > 2.5 volts  
Activation On/Off time: > 25 ms (3 seconds to arm for limit setup)

**Response Time:** 50 ms to 95% of final output value

### Indicators:

Green LED: Off when object is within range  
Amber LED: On when object is within window  
Red LED: Intensity varies directly with output magnitude

### Connections

Cable style models: (VM1 only)  
24 AWG, foil shield, lead-free, PVS jacket  
4-conductor, 3m (10') long  
Connector style models:  
12mm, circular 4-pole, male micro connector

### Protection

Power Supply: Current-limited over voltage, ESD, reverse polarity  
Output: Current-limited over voltage, ESD, over current  
Input: Current-limited over voltage, ESD, reverse polarity

### Environmental:

Operating Temperature:  $-30^\circ\text{C}$  to  $70^\circ\text{C}$  ( $-22^\circ\text{F}$  to  $158^\circ\text{F}$ )  
Storing Temperature Range:  $-40^\circ\text{C}$  to  $85^\circ\text{C}$  ( $-40^\circ\text{F}$  to  $185^\circ\text{F}$ )  
Operating Humidity: 100% non-condensing  
Protection Ratings: NEMA 4X (indoor use only), IP67  
Chemical Resistance: Resists most acids and bases, including most food products.

## Accessories

**Model PB100**, Inline push-button switch (for teaching window)

**Model AC130**, Straight, M12 micro, 4-conductor, connector/cable assembly, 5 m (16'), for micro-connector sensors

**Model AC132**, Right-angle, M12 micro, 4-conductor, connector/cable assembly, 5 m (16'), for micro connector sensors

**Model AC228**, Right-angle bracket

See page 7-1 for accessory photos.

## Standard Model Reference Guide - Virtu™ Analog Series

The following models represent normal functionality and analog minimum output state both on loss-of-echo and at power up.

VM1-VA  
VM1-VA-Q  
VM18-VA-Q

VM1-CA  
VM1-CA-Q  
VM18-CA-Q

### EXAMPLE MODEL:

**Analog Ultrasonic Series**

**Model Type**

1.....Dual Mount

18...18 mm Barrel

**Output Type**

V.....Voltage output ( 0-10 VDC default )

C.....Current output ( 4-20 mA default )

**Output Style**

A.....Auto slope ( default )

**Connection Type**

....No designator indicates 3 m (10') cable style connection

Q....Quick disconnect - 4-pin M12 "Micro" connector

**VM1-VA-Q**

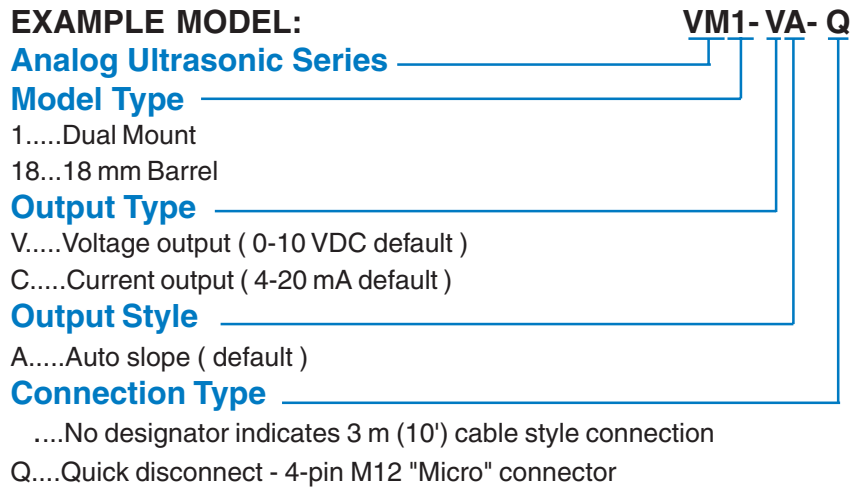

## Enhanced Reference Guide - Virtu™ Analog Series

Use the guide below to ensure the correct model number is specified for the application. Please note that not all sensor model combinations are available. Enhanced models are programmed for a particular application. These sensors are available at a different cost premium compared to the standard models.

### EXAMPLE MODEL:

VM1-VA3000- Q

#### Analog Ultrasonic Series

#### Model Type

- 1....Dual Mount
- 18...18 mm Barrel

#### Output Type

- V...Voltage output (0-10 VDC default)
- C...Current output (4-20 mA default)

#### Output Style

- A...Auto slope (default)
- I....Inverse slope
- D...Direct slope

#### Output State for Loss of Echo & Power-up State

- 0...Analog minimum
- 1...Analog maximum
- 2...Hold on loss-of-echo; analog minimum on power-up
- 3...Hold on loss-of-echo; analog maximum on power-up

#### Functionality

- 000...Normal functionality
- 001...Foreground suppression only (object mode)
- 002...Foreground suppression only (background mode)
- 003...Foreground & background suppression (background mode)
- 090...Output voltage 2 - 10 VDC
- 097...TAU = 32, Burst count =5, Loss-of-echo =300 cycles (1.5 sec)
- 098...TAU = 16, 240 ms response, 50 cycles Loss-of-echo delay - 250 ms
- 099...TAU = 8, 120 ms Response

#### Options

- ...No designator indicates no option
- AD...Teach function disabled

#### Connection Type

- ...No designator indicates 3 m (10') cable style connection
- Q...Quick disconnect - 4-pin M12 "Micro" connector

# Selection Chart

## VM Analog Series

Model No.	Materials					Outputs				Functionality				Notes
	Power Version 12/24 VDC	Quick Disconnect	Transducer Housing			Type								
			Epoxy	VALOX	PBT	Analog Minimum	Analog Maximum	Hold on loss-of-echo, analog minimum on power-up	Hold on loss-of-echo analog maximum on power-up	Normal functionality	Foreground suppression (object mode)	Foreground suppression (background mode)	Foreground & background suppression (background mode)	
VM1-VA-Q	■	■	■	■		■				■				
VM1-VA0001-Q	■	■	■	■		■					■			
VM1-VA0002-Q	■	■	■	■		■						■		
VM1-VA0003-Q	■	■	■	■									■	
VM1-VA1000-Q	■	■	■	■			■			■				
VM1-VA1001-Q	■	■	■	■			■				■			
VM1-VA1002-Q	■	■	■	■			■					■		
VM1-VA1003-Q	■	■	■	■			■						■	
VM1-VA2000-Q	■	■	■	■				■		■				
VM1-VA2001-Q	■	■	■	■				■			■			
VM1-VA2002-Q	■	■	■	■				■				■		
VM1-VA2003-Q	■	■	■	■				■					■	
VM1-VA3000-Q	■	■	■	■					■					
VM1-VA3001-Q	■	■	■	■					■		■			
VM1-VA3002-Q	■	■	■	■					■			■		
VM1-VA3003-Q	■	■	■	■					■				■	
VM1-VI-Q	■	■	■	■		■				■				
VM1-VI0001-Q	■	■	■	■		■					■			
VM1-VI0002-Q	■	■	■	■								■		
VM1-VI0003-Q	■	■	■	■		■							■	
VM1-VI1000-Q	■	■	■	■			■			■				
VM1-VI1001-Q	■	■	■	■			■				■			
VM1-VI1002-Q	■	■	■	■			■					■		
VM1-VI1003-Q	■	■	■	■			■						■	
VM1-VI2000-Q	■	■	■	■				■		■				
VM1-VI2001-Q	■	■	■	■				■			■			
VM1-VI2002-Q	■	■	■	■				■				■		
VM1-VI2003-Q	■	■	■	■				■					■	
VM1-VI3000-Q	■	■	■	■					■					
VM1-VI3001-Q	■	■	■	■					■		■			
VM1-VI3002-Q	■	■	■	■					■			■		
VM1-VI3003-Q	■	■	■	■					■				■	
VM1-VD-Q	■	■	■	■		■				■				
VM1-VD0001-Q	■	■	■	■		■					■			
VM1-VD0002-Q	■	■	■	■		■						■		
VM1-VD0003-Q	■	■	■	■		■							■	
VM1-VD1000-Q	■	■	■	■			■			■				
VM1-VD1001-Q	■	■	■	■			■				■			
VM1-VD1002-Q	■	■	■	■			■					■		
VM1-VD1003-Q	■	■	■	■			■						■	
VM1-VD2000-Q	■	■	■	■				■		■				
VM1-VD2001-Q	■	■	■	■				■			■			
VM1-VD2002-Q	■	■	■	■				■				■		
VM1-VD2003-Q	■	■	■	■				■					■	
VM1-VD3000-Q	■	■	■	■					■					
VM1-VD3001-Q	■	■	■	■					■		■			
VM1-VD3002-Q	■	■	■	■					■			■		
VM1-VD3003-Q	■	■	■	■					■				■	

\*(The VM1 dual-mount style models are also available in 10' cable length)



# Selection Chart

## VM Analog Series (cont.)

Model No.	Materials					Outputs				Functionality				Notes
	Power Version 12/24 VDC	Quick Disconnect	Transducer Housing			Type				Normal functionality	Foreground suppression (object mode)	Foreground suppression (background mode)	Foreground & background suppression (background mode)	
			Epoxy	VALOX	PBT	Analog Minimum	Analog Maximum	Hold on loss-of-echo, analog minimum on power up	Hold on loss-of-echo analog maximum on power up					
VM18-VA-Q	■	■	■	■	■					■				
VM18-VA0001-Q	■	■	■	■	■						■			
VM18-VA0002-Q	■	■	■	■	■							■		
VM18-VA0003-Q	■	■	■	■	■								■	
VM18-VA1000-Q	■	■	■	■	■		■			■				
VM18-VA1001-Q	■	■	■	■	■		■				■			
VM18-VA1002-Q	■	■	■	■	■		■					■		
VM18-VA1003-Q	■	■	■	■	■		■						■	
VM18-VA2000-Q	■	■	■	■	■			■		■				
VM18-VA2001-Q	■	■	■	■	■			■			■			
VM18-VA2002-Q	■	■	■	■	■			■				■		
VM18-VA2003-Q	■	■	■	■	■			■					■	
VM18-VA3000-Q	■	■	■	■	■				■					
VM18-VA3001-Q	■	■	■	■	■				■		■			
VM18-VA3002-Q	■	■	■	■	■				■			■		
VM18-VA3003-Q	■	■	■	■	■				■				■	
VM18-VI-Q	■	■	■	■	■	■				■				
VM18-VI0001-Q	■	■	■	■	■	■					■			
VM18-VI0002-Q	■	■	■	■	■	■						■		
VM18-VI0003-Q	■	■	■	■	■	■							■	
VM18-VI1000-Q	■	■	■	■	■	■				■				
VM18-VI1001-Q	■	■	■	■	■	■					■			
VM18-VI1002-Q	■	■	■	■	■	■						■		
VM18-VI1003-Q	■	■	■	■	■	■							■	
VM18-VI2000-Q	■	■	■	■	■	■			■					
VM18-VI2001-Q	■	■	■	■	■	■				■				
VM18-VI2002-Q	■	■	■	■	■	■					■			
VM18-VI2003-Q	■	■	■	■	■	■							■	
VM18-VI3000-Q	■	■	■	■	■	■			■					
VM18-VI3001-Q	■	■	■	■	■	■				■				
VM18-VI3002-Q	■	■	■	■	■	■					■			
VM18-VI3003-Q	■	■	■	■	■	■							■	
VM18-VD-Q	■	■	■	■	■	■				■				
VM18-VD0001-Q	■	■	■	■	■	■					■			
VM18-VD0002-Q	■	■	■	■	■	■						■		
VM18-VD0003-Q	■	■	■	■	■	■							■	
VM18-VD1000-Q	■	■	■	■	■	■				■				
VM18-VD1001-Q	■	■	■	■	■	■					■			
VM18-VD1002-Q	■	■	■	■	■	■						■		
VM18-VD1003-Q	■	■	■	■	■	■							■	
VM18-VD2000-Q	■	■	■	■	■	■			■					
VM18-VD2001-Q	■	■	■	■	■	■				■				
VM18-VD2002-Q	■	■	■	■	■	■					■			
VM18-VD2003-Q	■	■	■	■	■	■							■	
VM18-VD3000-Q	■	■	■	■	■	■			■					
VM18-VD3001-Q	■	■	■	■	■	■				■				
VM18-VD3002-Q	■	■	■	■	■	■					■			
VM18-VD3003-Q	■	■	■	■	■	■							■	