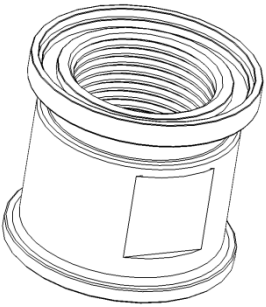
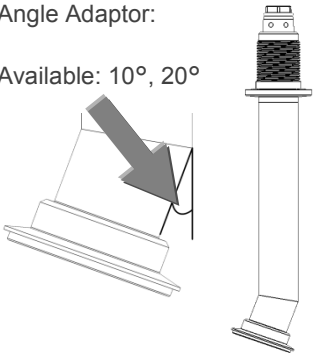
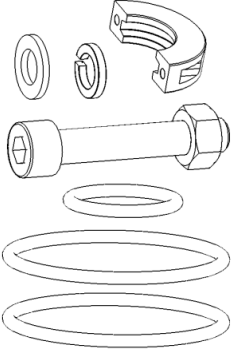
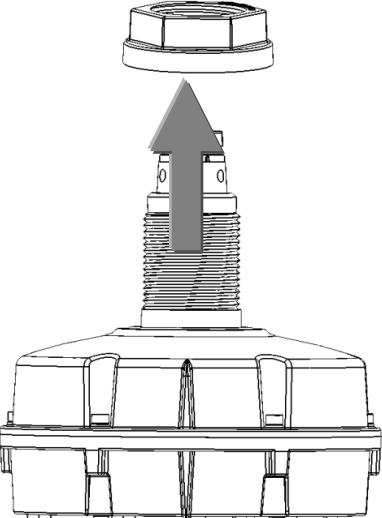
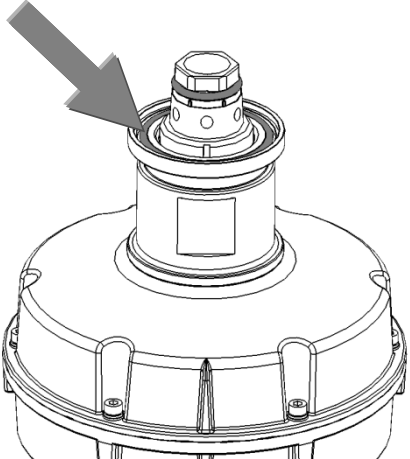
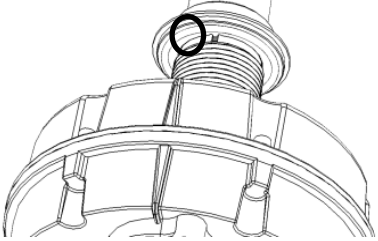
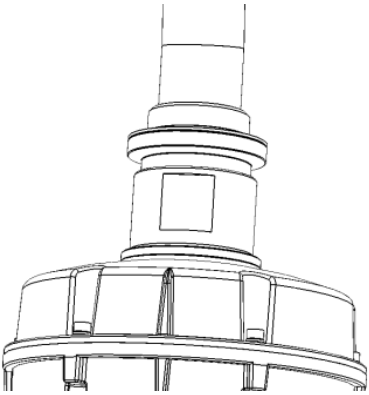
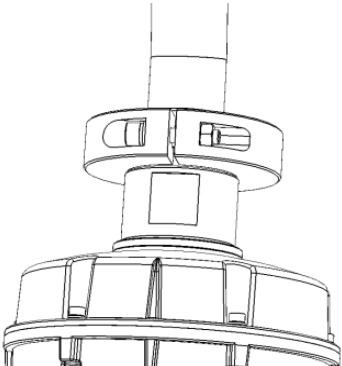
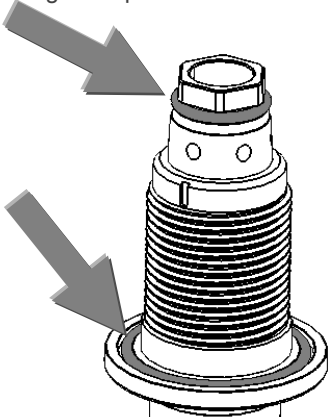
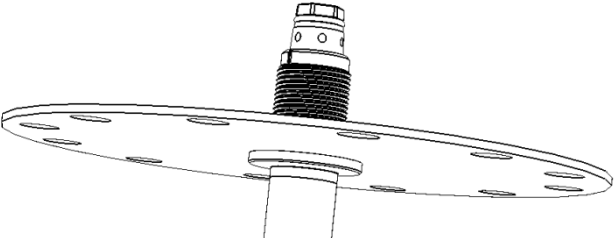
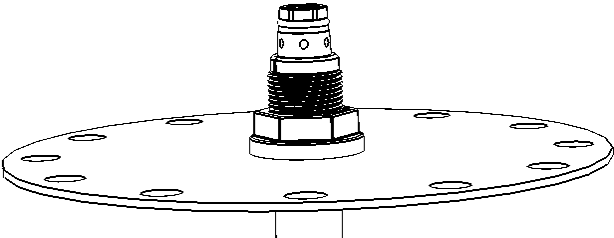

1 Angle Adaptor

1.1 Parts

<p>Angle Adaptor Nut:</p> 	<p>Angle Adaptor:</p> <p>Available: 10°, 20°</p> 	<p>Installation Kit:</p> <ul style="list-style-type: none"> 2 x Clamps 2 x M8 screws 2 x Nuts 2 x washers 2 x Large O-rings 1 x Small O-ring 	<p>i</p> <p>NOTE: It is advised to use APM 50cm Cable Extender or HT Scanner with 50cm extended cable.</p>
---	--	---	--

1.2 Assembly

<p>1 Remove Nut from horn assembly</p> 	<p>2 Screw all the way down the Angle Adaptor Nut Install the large O-ring in place</p> 	<p>3 Make sure the notch at the top of the angle adaptor is in the same direction as the horns The notch is designed to align the horns with the angle adaptor.</p> 
<p>4 Screw the Angle Adaptor nut up to the angle adaptor</p> 	<p>5 Place the clamps over the angle adaptor and the nut to lock them both together with the screws and nuts</p> 	<p>6 Fit the two O-rings on the top of the angle adaptor</p> 
<p>7 Fit flange over the Angle Adaptor</p> 	<p>8 Secure the Flange with the Nut</p> 	

9 Insert the assembled Scanner (with flange mounted) into the vessel and direct the scanner to the center of the vessel

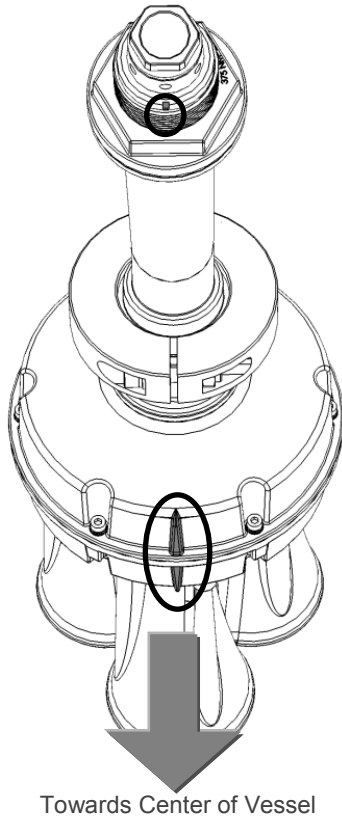

10 Mount the Scanner's head over the Angle Adaptor, see 3DLevelScanner Installation Manual for further information

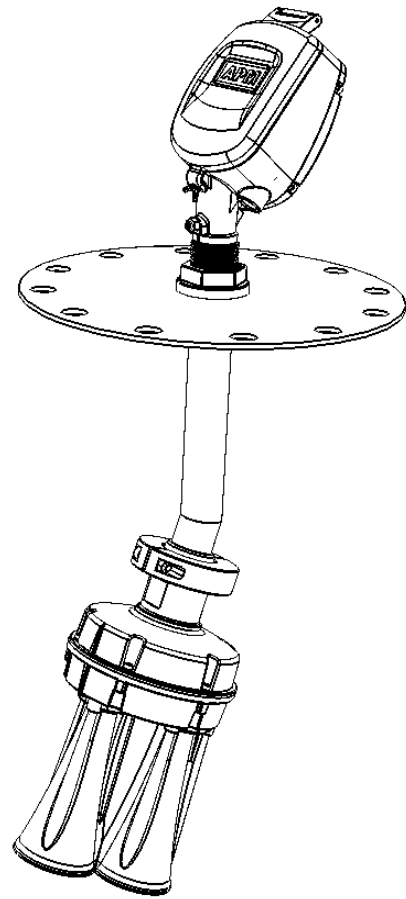

11 Following successful installation connect the 3DLevelScanner to the 3DLevelManager and configure the Angle Adaptor field (under Device→Advanced Parameters...) according to the actual installation, note that the angle can be between 0° to 30°:

