

INSTRUCTION MANUAL

Photoelectric Sensor Digital Laser Sensor Amplifier LS-400 Series

Thank you very much for using SUNX products. Please read this Instruction Manual carefully and thoroughly for the correct and optimum use of this product. Kindly keep this manual in a convenient place for quick reference.



- Never use this product as a sensing device for personnel protection.
- In case of using sensing devices for personnel protection, use products which meet standards, such as OSHA, ANSI or IEC etc., for personnel protection applicable in each region or country.
- Use of control or adjustment or performance of procedures other than those specified in this instruction manual may result in hazardous radiation expose.

1 SPECIFICATIONS

Item	Type		Connector type	Cable type
	Model No.	NPN Output		
		PNP Output	LS-401P	LS-401P-C2
Supply voltage			12 to 24V DC ± 10%	Ripple P-P 10% or less
Power consumption			Normal operation: 950mW or less (current consumption 40mA or less at 24V supply voltage) ECO mode: 780mW or less (current consumption 33mA or less at 24V supply voltage)	
Output (Output1, Output2)			<NPN output type> NPN open-collector transistor • Maximum sink current: 100mA (Note 1) • Applied voltage: 30V DC or less (between output and 0V) • Residual voltage: 1.5V or less (at 100mA (Note 1) sink current)	<PNP output type> PNP open-collector transistor • Maximum source current: 100mA (Note 1) • Applied voltage: 30V DC or less (between output and +V) • Residual voltage: 1.5V or less (at 100mA (Note 1) source current)
Output operation			Light-ON or Dark-ON, selectable with jog switch	
Short-circuit protection			Incorporated	
External input (Note 2)			<NPN output type> NPN non-contact input • Signal condition High: +5 to +V DC or open Low: 0 to 2V DC (source current 0.5mA) • Input impedance: 10kΩ approx.	<PNP output type> PNP non-contact input • Signal condition High: +4 to +V DC (sink current 3mA or less) Low: 0 to 0.6V DC, or open • Input impedance: 10kΩ approx.
Response time			H-SP: 80 μs or less, FAST: 150 μs or less, STD: 500 μs or less, U-LG: 4ms or less, selectable with jog switch	
Digital display			4 digit (green) + 4 digit (red) LED display	
Sensitivity setting	Normal mode	2-level teaching / Limit teaching / Full-auto teaching / Manual adjustment		
	Window comparator mode	Teaching (1, 2, 3 level) / Manual adjustment		
	Hysteresis mode	Teaching (1, 2, 3 level) / Manual adjustment		
	Differential mode	Five-level settings		
Fine sensitivity adjustment function			Incorporated	
Timer function			Incorporated with variable ON-delay/OFF-delay/ONE-SHOT timer, switchable either effective or ineffective (Timer period: 1ms~9999ms approx.)	
Interference prevention function			Incorporated (Up to four sensor heads can be mounted adjacently (However, in H-SP mode, the interference prevention function cannot be operated))	
Ambient temperature			-10 to +55°C (if 4 to 7 units are mounted closely, -10 to +50°C, if 8 to 16 units are mounted closely, -10 to +45°C) (No dew condensation or icing allowed), Storage: -20 to +70°C	
Ambient humidity			35 to 85% RH, Storage: 35 to 85% RH	
Material			Enclosure: Heat-resistant ABS, Transparent cover: Polycarbonate, Mode key switch: Acrylic, Jog switch: ABS	
Weight			15g approx.	65g approx.

- Notes: 1) 50mA max. if 5 to 8 units are connected in cascade, and 25mA max. if 9 to 16 units are connected in cascade
 2) External input is not incorporated with the connector type LS-401(P)
 3) The cable is not supplied as an accessory for connector type LS-401(P). Be sure to use the optional quick-connection cables given below.
 Main cable (4-core): CN-74-C1 (cable length 1m), CN-74-C2 (cable length 2m)
 CN-74-C5 (cable length 5m)
 Sub cable (2-core): CN-72-C1 (cable length 1m), CN-72-C2 (cable length 2m)
 CN-72-C5 (cable length 5m)

2 MOUNTING

How to mount the amplifier

- 1) Fit the rear part of the mounting section of the amplifier on a 35mm width DIN rail.
- 2) Press down the rear part of the mounting section of the unit on the 35mm width DIN rail and fit the front part of the mounting section to the DIN rail.



How to remove the amplifier

- 1) Push the amplifier forward.
- 2) Lift up the front part of the amplifier to remove it.

Note: Take care that if the front part is lifted without pushing the amplifier forward, the hook on the rear portion of the mounting section is likely to break.

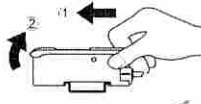

How to mount the sensor head

- 1) Insert the sensor head connector into the inlet until it clicks.
- 2) Fit the cover to the connector.

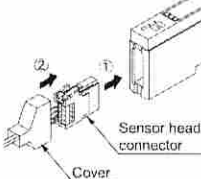

3 CAUTIONS

- Make sure that the power supply is off while wiring.
- Verify that the supply voltage variation is within the rating.
- Take care that if a voltage exceeding the rated range is applied, or if an AC power supply is directly connected, the sensor may get burnt or damaged.
- In case noise generating equipment (switching regulator, inverter motor, etc.) is used in the vicinity of this product, connect the frame ground (F.G.) terminal of the equipment to an actual ground.
- The ultra long distance (U-LG) mode is more likely to be affected by extraneous noise since the sensitivity of that is higher than the other modes. Make sure to check the environment before use.
- If power is supplied from a commercial switching regulator, ensure that the frame ground (F.G.) terminal of the power supply is connected to an actual ground.
- Do not use during the initial transient time (0.5 sec.) after the power supply is switched on.
- Take care that short-circuit of the load or wrong wiring may burn or damage the sensor.
- Do not run the wires together with high-voltage lines or power lines or put them in the same raceway. This can cause malfunction due to induction.
- Make sure to use the optional quick-connection cable for the connector type LS-401(P).
- Extension up to total 100m is possible with 0.3mm², or more, cable. However, in order to reduce noise, make the wiring as short as possible.
- This sensor is suitable for indoor use only.
- Avoid dust, dirt, and steam.
- Take care that the product does not come in direct contact with water, oil, grease, or organic solvents, such as, thinner, etc.
- This sensor cannot be used in an environment containing inflammable or explosive gases.
- Never disassemble or modify the sensor.

4 CASCADING CONNECTOR TYPE LS-401 (P)

For mounting and removing the amplifier, refer to '2 MOUNTING'.

Cascading method

- 1) Mount each amplifier one by one to 35mm width DIN rail and set the amplifiers to contact each other.
- 2) Insert the connector of quick-connection cable into the connector of the amplifier.
- 3) Mount the optional end plates (MS-DIN-E) at both the ends to hold the amplifiers between their flat sides.
- 4) Tighten the screws to fix the end plates (MS-DIN-E).

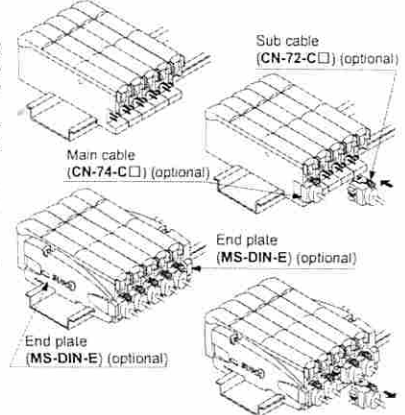

Dismantling method

- 1) Pressing the projection at the top of the quick-connection cable, pull out the connector.
- 2) Remove the amplifier.

5 I/O CIRCUIT DIAGRAM

● NPN output type

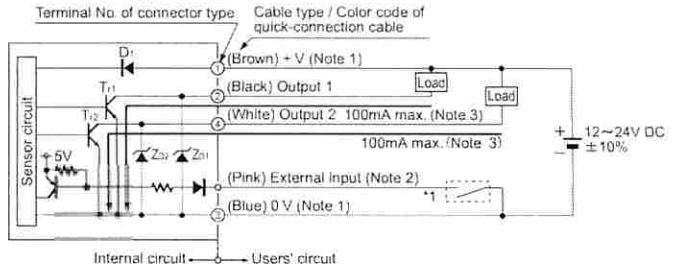

● PNP output type

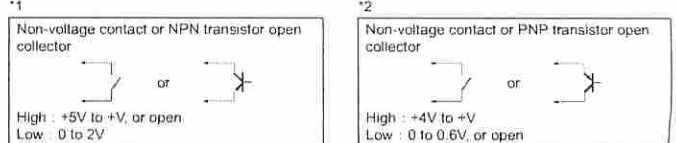
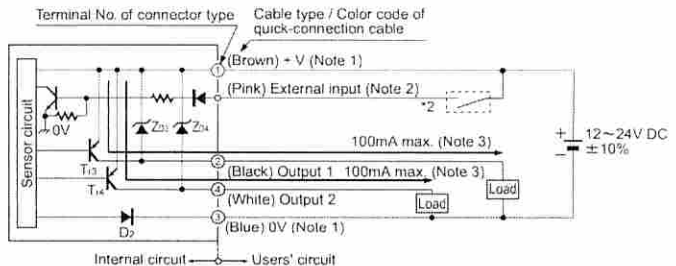

- Notes: 1) The quick-connection sub cable does not have +V (brown) and 0V (blue). The power is supplied from the connector of the main cable.
 2) External input is not incorporated with the connector type LS-401(P).
 3) 50mA max. if 5 to 8 units are connected in cascade, and 25mA max. if 9 to 16 units are connected in cascade

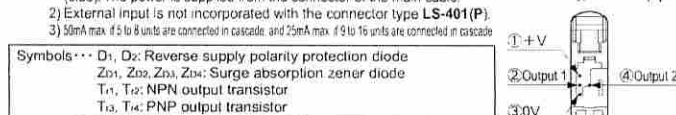

6 PART DESCRIPTION

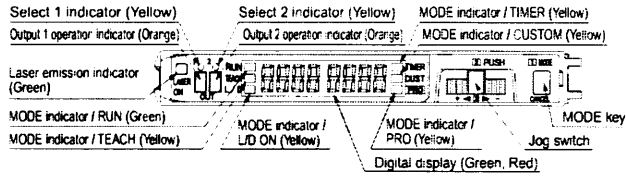

7 OPERATION PROCEDURE

MODE key		Jog switch	
Press	Press	Turn '+' side	Turn '-' side

- *1: When Jog switch is pressed, the setting is confirmed.
- *2: Cancellation is possible by pressing MODE key during setting.

- Be sure to set each item after selecting the output 1 or the output 2.
- The items that can be set in the output 1 and the output 2 respectively are only 1) Threshold value, 2) Output operation, 3) Timer operation and Timer period, and 4) Detection mode. The items other than those are common. (However, in case of setting with the direct code, a combination of the output 1/2 can be set only for output operation. The items other than output operation are valid only for the output 1.)

Procedures for switching the NAVI mode

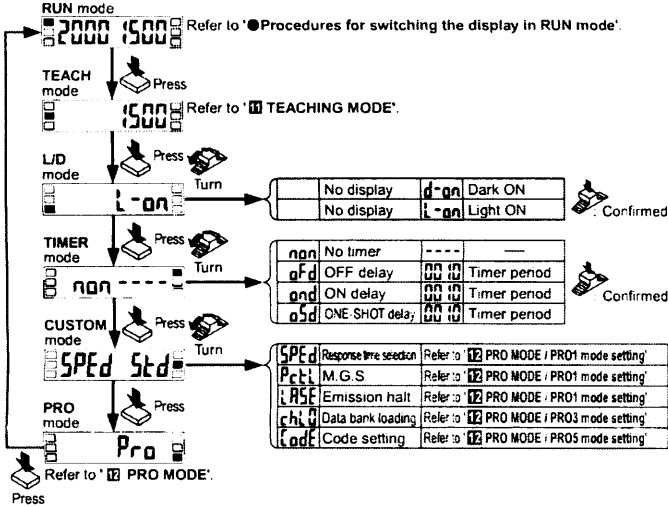

Procedures for switching the display in RUN mode

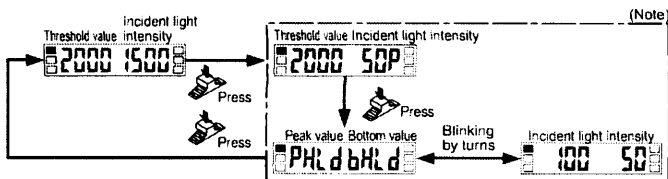

*Displayed only in Window comparator mode or Hysteresis mode and Differential mode.

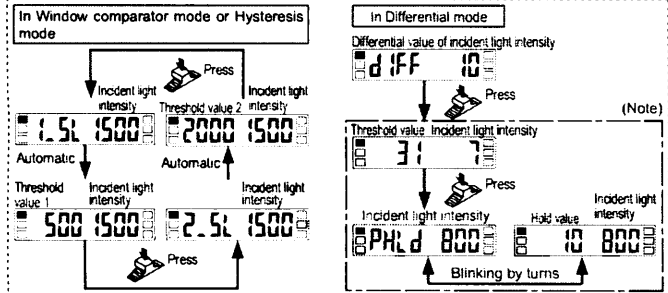

Note: Can be displayed if the display switching 'd' 'c' is set to 'off' to enable the display switching in PRO2 of PRO mode.

8 THRESHOLD VALUE FINE ADJUSTMENT FUNCTION

- The threshold can be fine-adjusted when the MODE indicator / RUN (green) lights up.
- Turn the jog switch to either '+' (left) or '-' (right) to increase / decrease the threshold value.



- * When you turn the jog switch to '+' or '-' in Window comparator mode or Hysteresis mode, the threshold will increase or decrease after the output 1 '1.SL' or the output 2 '2.SL' is displayed. If you turn the jog switch to '+' when the output 1 '1.SL' is displayed, the following will be displayed.

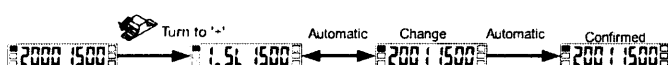

9 OUTPUT SWITCHING

- Press the MODE key for more than 2 seconds when in NAVI mode. If Output 1 has been selected, the Select 1 indicator (yellow) lights up. If the output 2 is being selected, the Select 2 indicator (yellow) lights up.

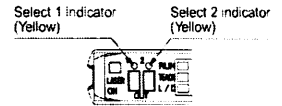

10 KEYLOCK FUNCTION

- If the jog switch and MODE key are pressed simultaneously for more than 3 seconds when the MODE indicator / RUN (green) is on, the key operation is locked. Press down for more than 3 seconds again to unlock the key.

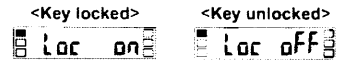

11 TEACHING MODE

When teaching in Window comparator mode or Hysteresis mode, a setting has to be made in PRO6 beforehand. In case of 1-level teaching, a shift value (the initial value is 100 digit or 15%) has to be set as well.

In case of 2-level teaching

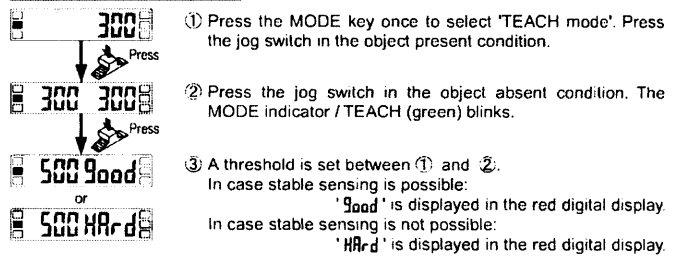

In case of Limit-teaching

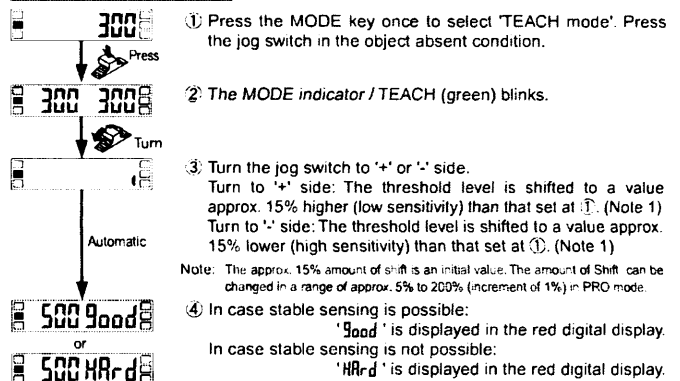

In case of Full-auto teaching

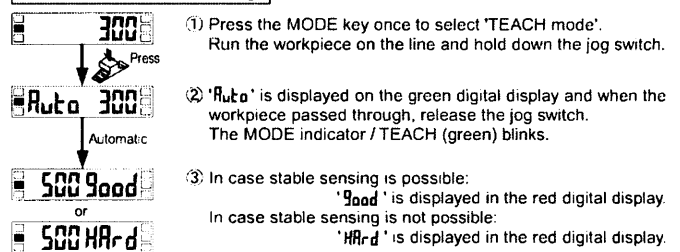

In case of 1-level teaching in Window comparator mode or Hysteresis mode

- This is the method to set the shift value to the desired value and set the threshold range by using the single-point teaching.

<Window Comparator mode>

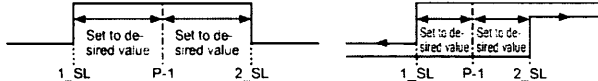

<Hysteresis mode>

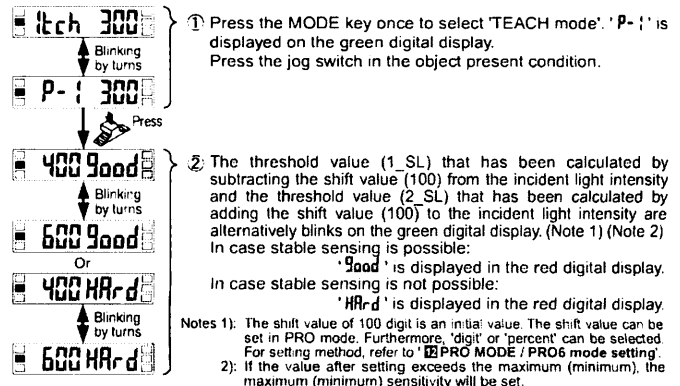

- Notes 1): The shift value of 100 digit is an initial value. The shift value can be set in PRO mode. Furthermore, 'digit' or 'percent' can be selected. For setting method, refer to 'PRO MODE / PRO6 mode setting'.
- 2): If the value after setting exceeds the maximum (minimum), the maximum (minimum) sensitivity will be set.

PRO MODE

● When MODE indicator / PRO (yellow) lights up, PRO mode can be set.

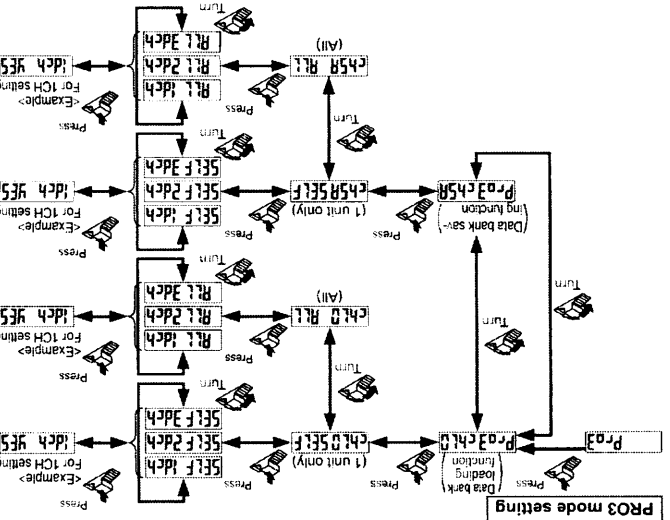
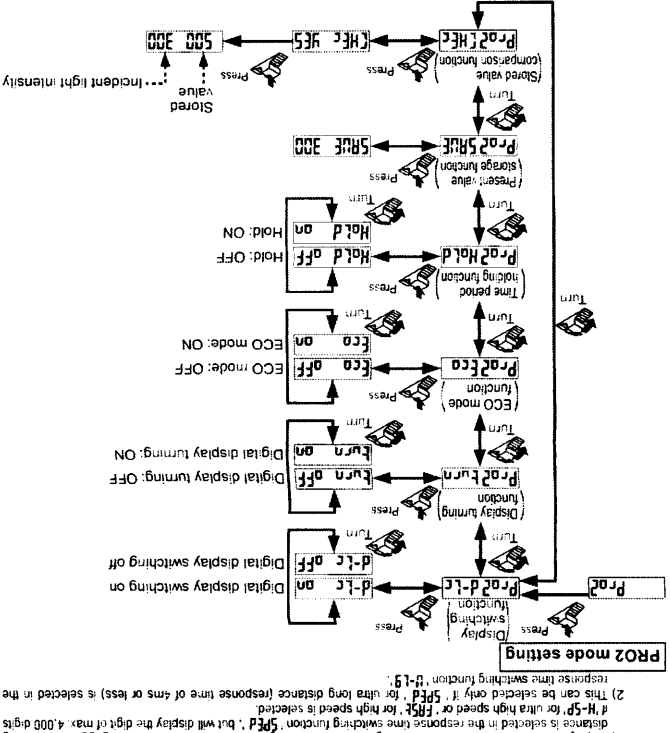
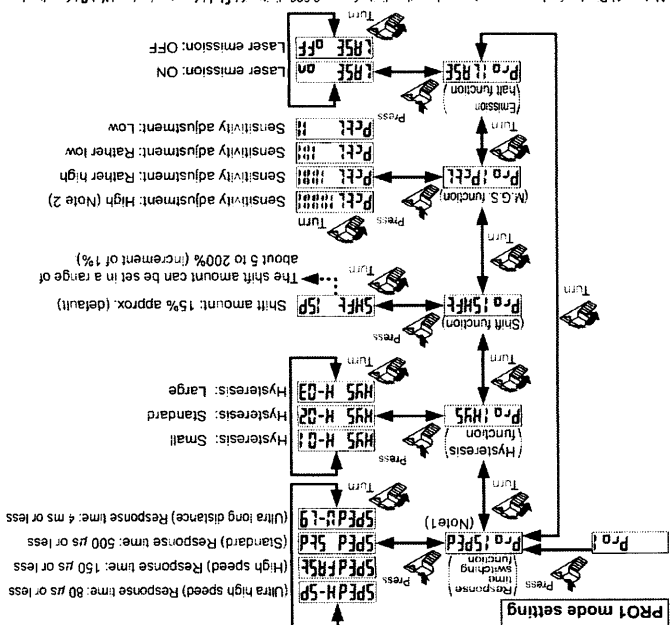

In case of 2-level teaching in Window Comparator mode or Hysteresis mode

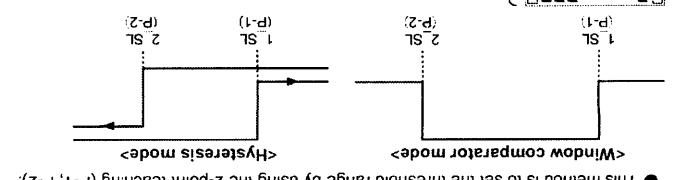

In case of 3-level teaching in Window Comparator mode or Hysteresis mode

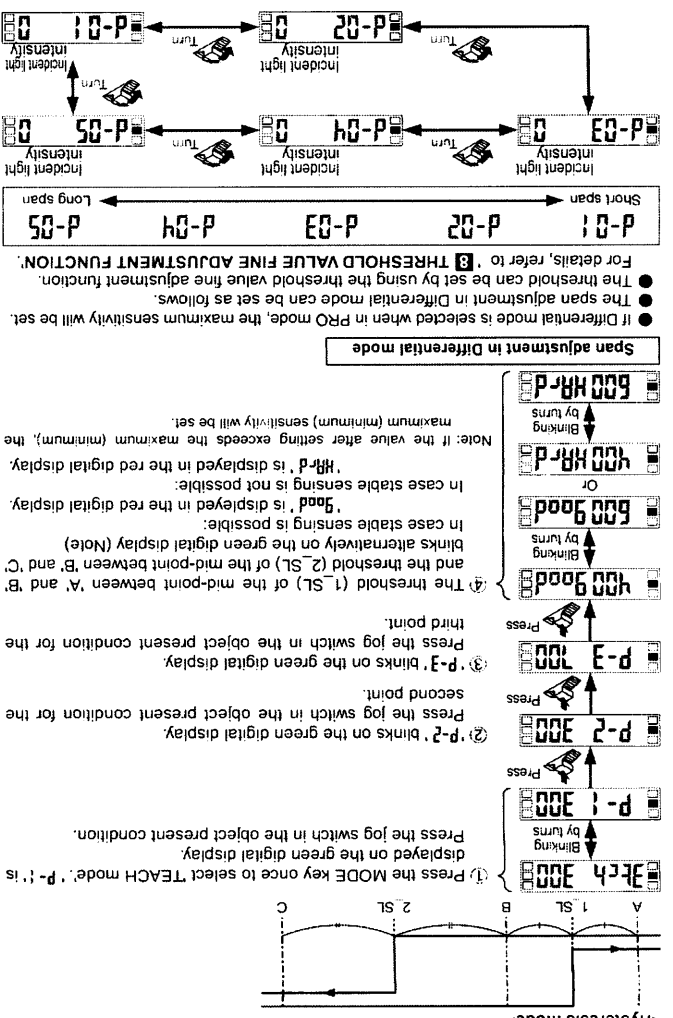
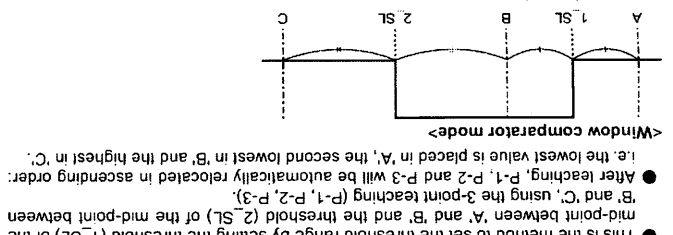

PRO4 mode setting

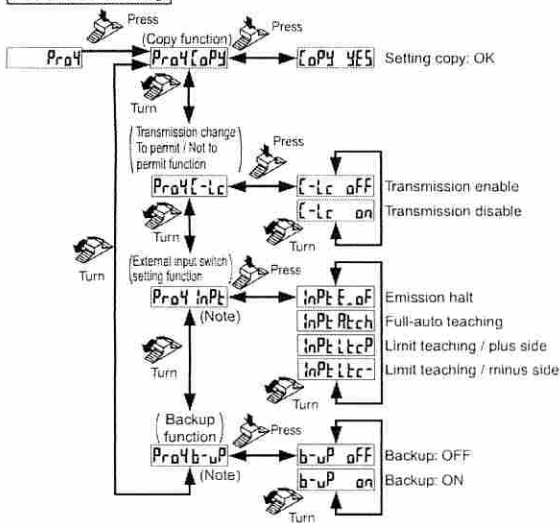

Note: This indication is not shown on the connector type LS-401(P).

PRO5 mode setting

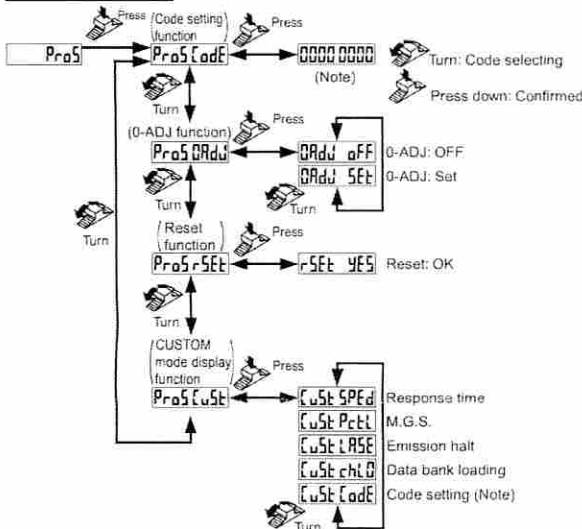

Note: Refer to '13 LIST OF CODE SETTING' when using the code setting function.

PRO6 mode setting

● Output 1

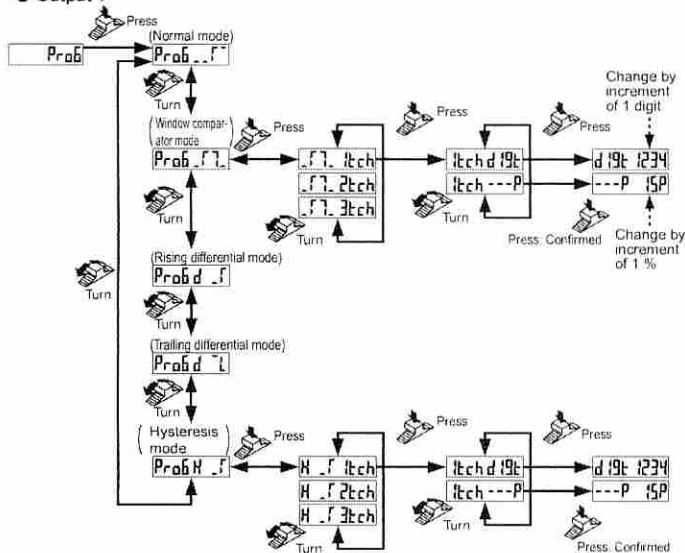

● Output 2

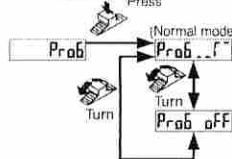

13 LIST OF CODE SETTING

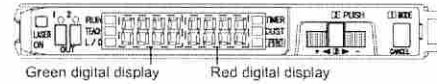

● Green digital display

Direct code	First digit	Second digit	Third digit	Fourth digit
0	L/D switching (Output 1, Output 2)	Timer operation	Response time	Sensitivity setting
0	L-ON·L-ON	0 Off	0 STD	0
1	L-ON·D-ON	1 On delay	1 H-SP	1
2	D-ON·L-ON	2 Off delay	2 FAST	2
3	D-ON·D-ON	3 One-shot delay	3 U-LG	3
4	---	4 ---	4 ---	4 ---
5	---	5 ---	5 ---	5 ---
6	---	6 ---	6 ---	6 ---
7	---	7 ---	7 ---	7 ---
8	---	8 ---	8 ---	8 ---
9	---	9 ---	9 ---	9 ---

● Red digital display

Direct code	First digit	Second digit (Note)	Third digit	Fourth digit
Direct code	Hyster-esis	Copy lock	External input	Custom
0	H-02	OFF	0 Laser emission halt	0 Response time
1	H-02	ON	1 Laser emission halt	1 M.G.S.
2	H-03	OFF	2 Auto teaching	2 Data bank loading
3	H-03	ON	3 Auto teaching	3 Emission halt
4	H-01	OFF	4 Limit +	4 D code
5	H-01	ON	5 Limit +	5 ---
6	---	---	6 Limit -	6 ---
7	---	---	7 Limit -	7 ---
8	---	---	8 ---	8 ---
9	---	---	9 ---	9 ---

The highlighted line indicates the default code (factory setting).

Note: Connector type LS-401 (P) shows only '0'.

14 ERROR DISPLAY

Take the following actions in case of errors.

Display	Description of error	Action
Er-1	Overcurrent has been applied due to short-circuited load.	Turn off the power supply and check the load.
Er-4	Disconnection error of sensor head.	Check the connection of sensor head.
Er-5	Transmission error during connection.	Verify that there is no loose or clearance between amplifiers.

15 OPTICAL COMMUNICATION

When the collective data bank load / save function or copy function is used via optical communication, loading / saving or copy of the setting can be carried out only to the amplifiers (sub units) connected on the right side of the amplifier (main unit), as shown in the figure below. However, if the amplifier (sub unit) is being connected (the indicator blinks), PRO mode is being set or the transmission enable / disable function is set to 'disable', loading / saving or copy is not carried out. Furthermore, the sensing operation stops during optical communication.

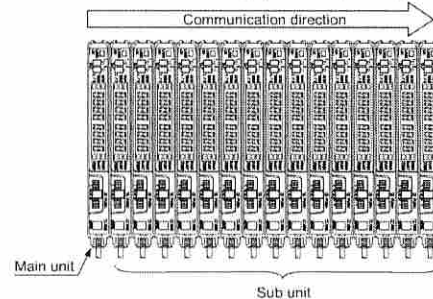

SUNX Limited

<http://www.sunx.co.jp/>

Head Office

2431-1 Ushiyama-cho, Kasugai-shi, Aichi, 486-0901, Japan

Phone: +81-(0)568-33-7211 FAX: +81-(0)568-33-2631

Overseas Sales Dept.

Phone: +81-(0)568-33-7861 FAX: +81-(0)568-33-8591

PRINTED IN JAPAN