

General Specifications

Power Supply:	
Supply Voltage:	+12 to 24 VDC
Transmitter Current:	30 mA maximum (For Transmitter only)
Temperature:	
Operating Temperature:	0°C to 60°C (32°F to 140°F), @ 100% relative humidity
Storage Temperature:	-10°C to 80°C (14°F to 176°F)
Sensing Range:	See model range table in operation figure
Dimensions:	
Threads:	1 1/4 x 18 unef
Length:	73.00 mm (2.875 in.)
Cable:	2.5 Meters (10 ft.) Standard
Materials:	
Housing:	Stainless Steel
Transducer face:	RTV
Cable:	Non-toxic PVC jacket
Environmental Ratings:	NEMA 4x, IP67

MICROSONIC®

Hyde Park
Sensors for the Real World

SM139

Thru-beam Transmitter Cable Style

OPERATOR INSTRUCTIONS

This Hyde Park ultrasonic, thru-beam transmitter, when paired with a compatible receiver is capable of sensing nearly any object, even transparent materials such as glass, plastic, and clear film.

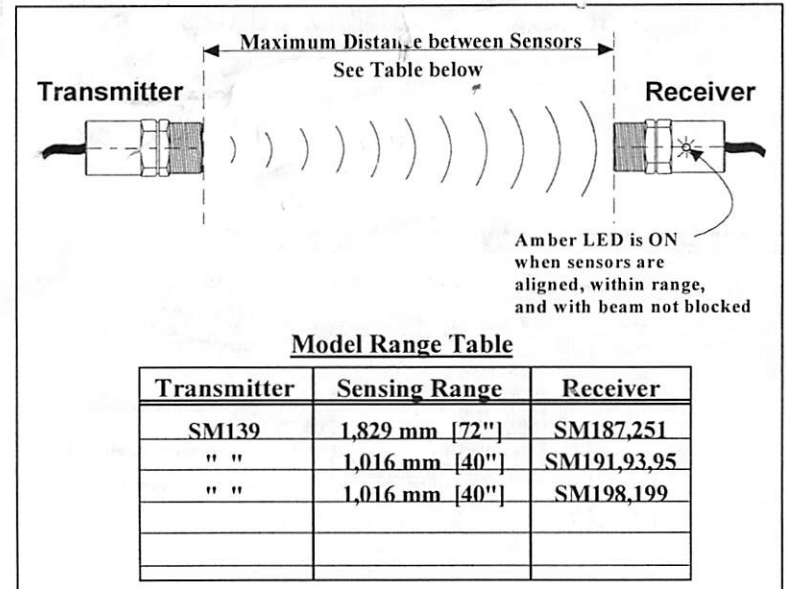

Figure 1.

LIMITATIONS AND EXCLUSION OF WARRANTIES

All goods purchased from Hyde Park Electronics LLC shall be free from defects in materials, design and workmanship under normal conditions of use for one year from the date of shipment. THIS WARRANTY IS THE SOLE WARRANTY AND IS EXPRESSLY IN LIEU OF ALL OTHER WARRANTIES, EXPRESS OR IMPLIED, INCLUDING BUT NOT LIMITED TO ANY IMPLIED WARRANTY OF MERCHANTABILITY OF FITNESS FOR A PARTICULAR PURPOSE. THE LIABILITY OF HYDE PARK TO ANY PURCHASER SHALL BE LIMITED EXCLUSIVELY TO THE COST OF REPLACEMENT OR REPAIR OF DEFECTIVE PARTS, AND SHALL NOT INCLUDE LIABILITY FOR ANY DIRECT, CONSEQUENTIAL OR INCIDENTAL DAMAGES WHATSOEVER, WHETHER FORESEEN OR UNFORESEEN, INCLUDING BUT NOT LIMITED TO LOST PROFITS, LOST SALES, OR INJURY TO PERSONS OR PROPERTY.

HYDE PARK ELECTRONICS LLC

1875 Founders Drive
Dayton, Ohio 45420-4017
Phone (937) 252-2121 Fax (937) 258-5830
Email: help@sesensors.com
Web Site: http://www.sesensors.com

© 1998-2006 Hyde Park Electronics LLC

Literature and application engineering assistance is provided by Hyde Park and its authorized distributors to aid the customer in selecting the product for an application. The customer, however, is responsible for determining the suitability of the product in the application.

Mounting / Alignment

Mount the sensor so that both transmitter and receiver are aligned opposite each other. The receiver's LED must be on when no object is blocking the sonic energy from the transmitter.

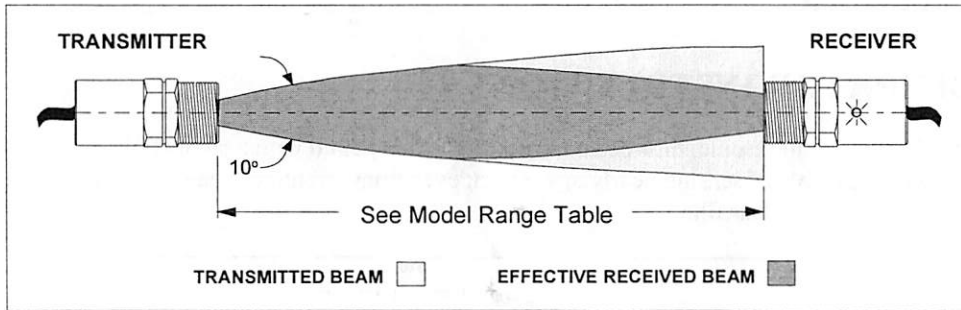

Transmitter Dimensions, Wiring connections

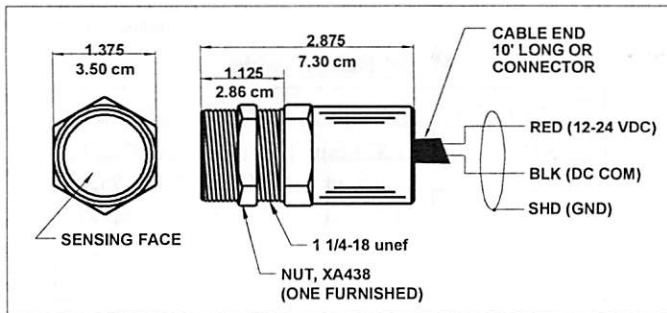

Accessories

Model AC201

Thru-Beam Bracket

Mounting Bracket Dimensions

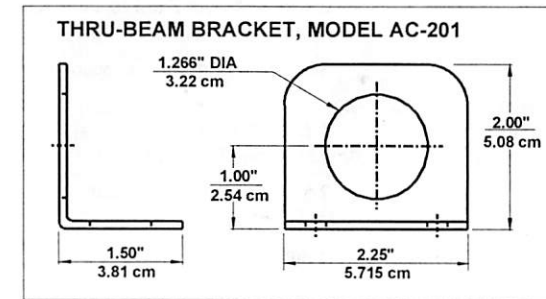

Other models available for either thru-beam or break-beam sensing considerations.

MICROSONIC® continuous-wave/thru-beam sensors
Model SM100 series (including the model in these instructions)
Model SM100 CE-certified series
Model SM800 CE-certified, 18 mm barrel or flat-profile

SUPERPROX® pulse-echo/reflective break-beam sensors
Model SM500 CE-certified, proximity with no delay (background mode)
Model SM503 CE-certified, proximity with delay (background mode)

See catalog for specifications or contact your Distributor or Hyde Park.