

**DB 12...**

**Double Sheet Testing Unit**



Part No. 501 11713



18 - 30 V

DC

- Reliable detection of multi-layer paper and plastic sheets as well as metal foils
- Measurement range from 20g paper to 1200g cardboard
- Automatic and manual calibration
- Ultrasonic sensor in the M18 round-sleeve housing
- Plug connection
- Short-circuit proof PNP or NPN transistor output
- Operating state indicated by means of LEDs
- Very short construction (can thus be used in applications with limited available space)



**Accessories:**

(available separately)

- M12 connectors, 5-pin:  
KB-095-5000-5A  
Part No.: 500 20499
- M12 connectors, 8-pin:  
KB-448-5000-8A  
Part No.: 500 33061

We reserve the right to make changes \* db\_12\_gp.fm

**Dimensioned drawing**

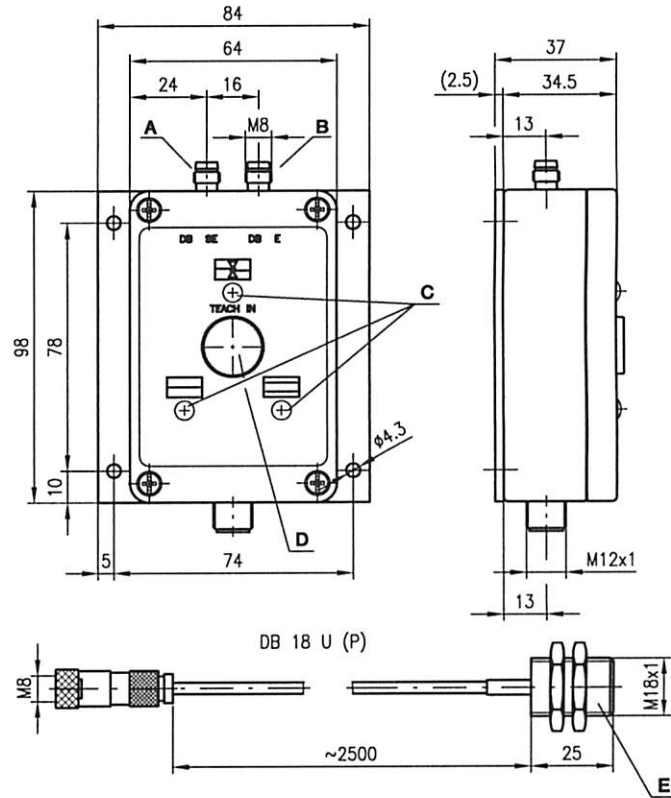

- A Transmitter DB 18 U (P)
- B Receiver DB 18 U (P)
- C Indicator diodes
- D Push button "TEACH IN"
- E optionally 42mm internal: mode switch

**Electrical connection**

**VDB 12/4.4**

18-30V DC+	1	br/BN
Einzelbogen/singlesheet	2	ws/WH
GND	3	bl/BU
Doppelbogen/doublesheet	4	sw/BK
Teach IN	5	qr/GR

**VDB 12/4.5**

18-30V DC+	1	ws/WH
Einzelbogen/singlesheet	2	br/BN
GND	3	gn/GN
Doppelbogen/doublesheet	4	qr/YE
Teach IN	5	qr/GR
Trigger IN	6	rs/PK
Trigger OUT	7	bl/BU
Bereitschaft/Level ok	8	rt/RD

**VDB 12/2.2**

18-30V DC+	1	br/BN
Einzelbogen/singlesheet	2	ws/WH
GND	3	bl/BU
Doppelbogen/doublesheet	4	sw/BK
Teach IN	5	qr/GR

**VDB 12/2.5**

18-30V DC+	1	ws/WH
Einzelbogen/singlesheet	2	br/BN
GND	3	gn/GN
Doppelbogen/doublesheet	4	qr/YE
Teach IN	5	qr/GR
Trigger IN	6	rs/PK
Trigger OUT	7	bl/BU
Bereitschaft/Level ok	8	rt/RD

**Specifications**

<b>Sensor data</b>	<b>DB18 UP</b>	<b>VDB 12/4 .4</b>
Operating range	20 ... 60mm	
Converter frequency	200kHz ±2%	
Sound cone	approx. 12°	
<b>Timing</b>		
Switching frequency		200Hz
Input pulse		min. 5ms
Delay before start-up		≤ 100ms
<b>Electrical data</b>		
Operating voltage $U_B$		18 ... 30VDC (incl. residual ripple)
Residual ripple		≤ 15% of $U_B$
Bias current		≤ 75mA
Switching output		2 PNP transistor outputs
Function		single sheet detected, or ≥ 1 sheet double sheet detected, or ≥ 2 sheets
Signal voltage high/low		≥ ( $U_B - 2V$ ) / ≤ 2V
Output current		max. 200mA per output
TEACH-/TRIGGER input		$R_{in} = 10k\Omega$
TEACH-/TRIGGER IN active/not active		≥ 6V / ≤ 2V or not connected
TEACH-/TRIGGER IN duration		max. 100ms
TEACH IN delay <sup>1)</sup>		approx. 300ms for S2="0"
<b>Indicators</b>		
LED A, green		double sheet testing unit ready
LED A, flashing green		teach-in event
LED B, yellow		single sheet detected
LED C, red		double sheet detected
<b>Mechanical data</b>		
Housing	nickel-faced brass	aluminum, powder coated black
Weight	30g	400g
Connection type	2.5m cable with M8 connector, 3-pin	M 12 connector, 5-pin
<b>Environmental data</b>		
Ambient temp. (operation/storage)		0°C ... +60°C / -40°C ... +70°C
Protective circuit <sup>2)</sup>		1,2,3
VDE safety class		III
Protection class		IP 65
Standards applied		EN 60947-5-2

1) Only applies for automatic calibration during sheet movement  
2) 1=transient protection, 2=polarity reversal protection, 3=short circuit protection

**Order guide**

	<b>Type</b>	<b>Part No.</b>
Sensor pair M18 x 25mm	DB 18 UP.1-25,2500	501 08998
Sensor pair M18 x 42mm	DB 18 UP.1-40,2500	501 08997
Amplifier (PNP switching output)	VDB 12/4.4	500 37525
Amplifier (PNP switching output) Same output behaviour as VDB 12/4 i.e. the single sheet output is not active when a double sheet is detected	VDB 12/4.4.1	501 02349
Amplifier with TRIGGER input (PNP switching output)	VDB 12/4.5	500 38111
Amplifier with TRIGGER input (NPN switching output)	VDB 12/2.5	500 40886
Amplifier with switching delay	VDB 12/2.2	500 33383

**Tables**

**Diagrams**

**Note**

**DB 12...**

**Technical data for other types**

**Additions and differences compared to VDB 12/4**

<p>Switching output TEACH IN/TRIGGER active/not active Response delay for double sheet output</p>	<p><b>VDB 12/2.2</b> 2 NPN transistor outputs ≤ 2V / ≥ 6V or not connected 0 ... 100ms, adjustable</p>	<p><b>VDB 12/2.5</b> 4 NPN transistor outputs single sheet detected double sheet detected double sheet triggered <sup>2)</sup> double sheet testing unit ready <sup>3)</sup> ≥ 1 ms ready inquiry signal TRIGGER IN double sheet triggered M12 connector, 8-pin</p>
<p>Switching output Function</p>	<p><b>VDB 12/4.5</b> 4 PNP transistor outputs single sheet detected double sheet detected double sheet triggered <sup>1)</sup> double sheet testing unit ready <sup>3)</sup> ≥ 1 ms ready inquiry signal TRIGGER IN double sheet triggered M12 connector, 8-pin</p>	<p><b>VDB 12/2.5</b> 4 NPN transistor outputs single sheet detected double sheet detected double sheet triggered <sup>2)</sup> double sheet testing unit ready <sup>3)</sup> ≥ 1 ms ready inquiry signal TRIGGER IN double sheet triggered M12 connector, 8-pin</p>
<p>TRIGGER OUT Ready / Level ok TRIGGER IN pulse duration LED D, yellow LED E, yellow LED F, red Connection type</p>		

- 1) Gets set during low/high transition of the TRIGGER IN input and reset when the measurement field becomes vacant. Trigger delay ≤ 1 ms, i.e., response time from edge until switching of the switching output is ≤ 1 ms
- 2) Gets set during high/low transition of the TRIGGER IN input and reset when the measurement field becomes vacant. Trigger delay ≤ 1 ms, i.e., response time from edge until switching of the switching output is ≤ 1 ms
- 3) Gets set when the operating voltage is applied, subject to sufficient signal level at receiver

**Controls and indicators**

- A Green LED
- B Yellow LED
- C Red LED
- D Yellow LED
- E Yellow LED
- F Red LED
- G Response delay: adjustment of switching delay (for VDB 12/2.2 only)
- S1 Switch: Teach/Ref. constant
- S2 Switch: Teach man./auto

VDB 12/4.4  
VDB 12/2.2

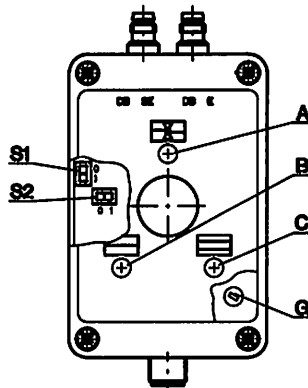

VDB 12/4.5  
VDB 12/2.5

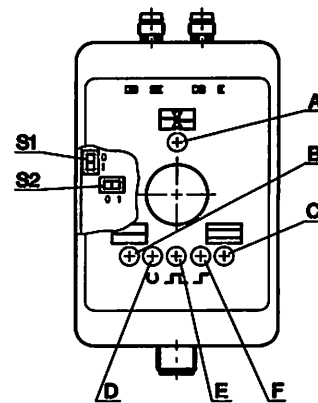

**Mounting and notes**

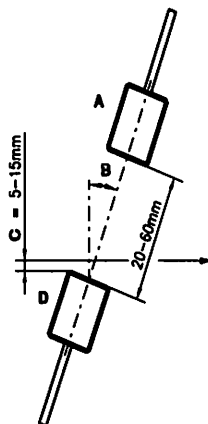

- A Receiver
- B Angle of inclination
- C Sheet material
- D Transmitter

**Note**

- When aligning transmitter and receiver, care must be taken to align them as exactly as possible. To achieve proper functionality, the sensors must be tilted towards the normal by an angle "B".

Sheet material	Recomm. angle of inclination B		
	0°	15° ... 25°	25° ... 35°
Standard paper up to 150g/m <sup>2</sup>	X	X	X
Cardboard		X	X
Plastics			X

## Technical description

### General

The Ultrasonic Double Sheet Testing system consists of an analysis amplifier VDB 12... and an ultrasonic sensor pair DB 18 UP. It checks primarily paper, plastic and metal foils which are mostly guided in by feeders. Each sheet is compared with a reference value stored in memory and, in the case of a double sheet, indicated appropriately.

### Mounting

Transmitter and receiver (DB 18 UP) are constructed identically and must be mounted at an angle. This angle depends on the sheet material used and is specified in the table in the section "Installation and remarks". A larger angle of inclination increases the flutter range. E.g., at a 40° pitch, fluttering within 60% of the measurement field is allowed. The minimum distance between the transmitter and receiver is 20mm and the maximum distance is 60mm.

Exact alignment ( $\pm 1^\circ$ ) must be ensured. Alignment which is not in line with the axis results in a reduction of the working range.

### Function

Referencing possibilities (calibrate or Teach)

- To achieve a secure detection of double sheets for all materials to be processed, it is recommended to always use the single medium as a reference. Switch S1 in position "1" (Teach).
- In the case of inhomogenous materials, e.g., materials with trapped air or high bulk paper, the referencing can fluctuate significantly depending on the scanning location during the calibration. These materials can be checked using a constant reference value (Ref. constant). "S1"-switch in "0"-position (Ref. constant)

The analysis unit can be operated in two different referencing modes.

- **a) Switch S2 in position "1" (man.)**  
A calibration with the material to be detected can be performed either by pressing the "TEACH IN" button on the top of the device or by means of a control command sent to the "TEACH IN" input. The reference value remains stored until the next calibration process.
- **b) Switch S2 in position "0" (Auto)**  
Calibration as described under "a)", as well as automatic "TEACH IN" during sheet intake and when applying the supply voltage if a sheet is located between the sensors at this time. An automatic calibration process is performed during sheet entry if no sheet is present in the measurement field for  $\geq 2$ s.

### Operation

The evaluation unit VDB 12/4.4 or .../2.2 continuously signals the situation between the sensors via two outputs.

The "single sheet detected" output is activated as long as one or more sheets are in the measurement field.

The "double sheet detected" output is activated as long as two or more sheets are in the measurement field.

For the evaluation units VDB 12/4.5 or .../2.5, there is also a query input "TRIGGER IN", a double sheet output "TRIGGER OUT" that is saved at the time of the query, and a "ready" output available. If a double sheet is detected during a positive (.../4.5) or negative (.../2.5) edge of the query, the output "TRIGGER OUT" is set. It remains set until the ultrasound path is cleared.

The "ready" output is set if there is sufficient received signal level when the operating voltage is supplied.

It remains set until the next calibration!

The reference value remains saved even after an interruption in the voltage supply.

For this version VDB 12/2.2, the response time of the "double sheet detected" output can be set via a potentiometer.