

# Bimetal Thermometer/Thermowell Assembly

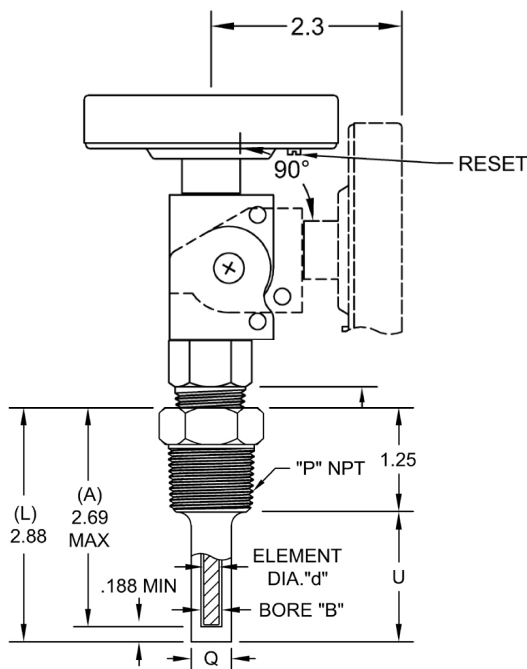
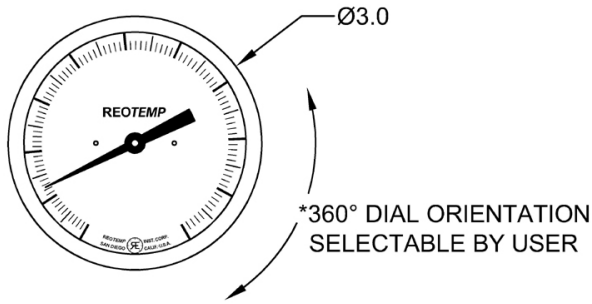

NOTES/(UNLESS OTHERWISE SPECIFIED)  
 1) DIMENSIONS ARE IN INCHES  
 2) DIMENSIONS ARE SUBJECT TO CHANGE

THERMOWELL, (LIMITED SPACE) WITH:  
 - THREADED PROCESS CONNECTION  
 - STRAIGHT SHANK

<b>Bimetal Part #:</b>	LL0251C43-
<b>Description:</b>	Industrial Bimetal Dial Thermometer, 3" Dial, Adjustable Angle/Reset, 2.5" Stem, 1/2" NPT (fits std. thermowell), 0/100°C
<b>Thermometer Data:</b>	
Dial Size/ Configuration:	3" Dial, Adjustable Angle/Reset
Stem Length, "A" :	2.5 in. (64mm)
Stem Dia., "d" :	1/4"
Process Connection:	1/2" NPT (fits std. thermowell)
Temperature Range:	0/100°C
Accuracy:	+/- 1% of full scale
Actuation	Bimetal coil in stem
Sealing	Hermetically Sealed per ASME B40.3

<b>Thermowell Part #:</b>	<b>ST2.5304</b>
<b>Material 304 Stainless (std)</b>	
<b>Dimensions (inches):</b>	
Bore Dia.	B: .260" bore, for 1/4" dia. Element
Element Length	A: 2.5"
Overall Length	L: 2.88"
Insertion Length	U: 1.63"
Process	P: 3/4" NPT (std)
Shank dia.	Q: .500"
<b>Options Included (not depicted in Dwg.)</b>	
Option 1:	
Option 2:	
Option 3:	
Option 4:	

<b>Revision Status:*</b>	Data generated on:	1/16/2015
Latest Revision:	x1	Revision Date: 11/1/2012
Description:	Initial Release	

\*Revision date applies to all possible data: Individual drawings may not be affected. To obtain current revision, re-generate drawing at [www.reotemp.com](http://www.reotemp.com).

Part Name: LL0251C43--ST2.5304		REOTEMP Instrument Corporation 10856 Roselle Street San Diego, CA 92121 USA Phone: (858) 784-0710 Fax: (858) 784-0720		DATE SEE ABOVE DRAWN BY JR APPROVED
UNLESS OTHERWISE SPECIFIED DIMENSIONS ARE IN INCHES TOLERANCES ARE: FRACTIONS DECIMALS ANGLES ± 1/32 .X ± .2 ± 5° .XX ± .01 .XXX ± .005	SIZE B	CAGE CODE: 24793	DWG NO. SEE ABOVE	
File Control BH-LL BCTW-1J A-TM	Copyright © 2012 REOTEMP Instruments	SCALE: NTS	FILE NAME:	SHEET 1 OF 1