

Model SM607 Series

SUPERPROX® Ultrasonic Proximity Sensors

Small Target Sensing

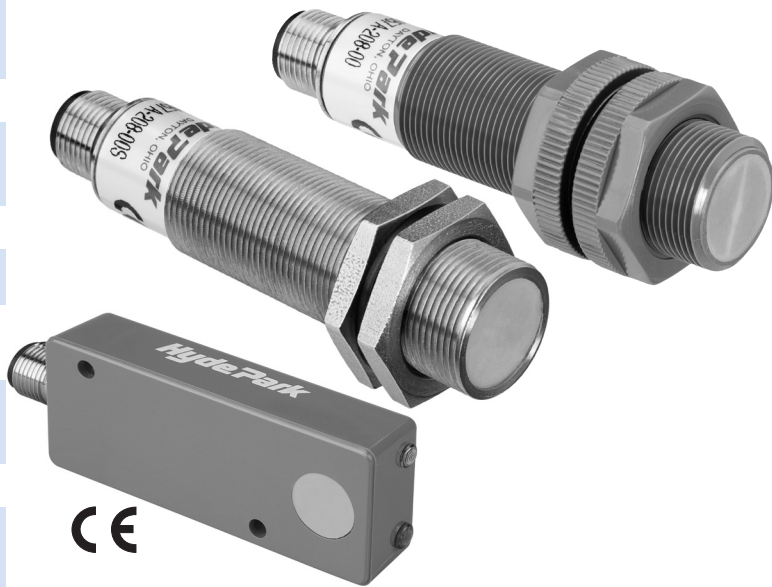

This fast, high-gain, ultrasonic proximity sensor detects objects as small as 0.076 mm (0.003") in width at a speed of 400 inches per second.

Where very small target sensing applications require fast, repeatable, reliable, and precise on/off control, the high-frequency, fixed-window SUPERPROX® Model SM607 series ultrasonic proximity sensors are the ideal solution. Combining new and unique piezoelectric transducer and microprocessor technology, this “tough little prox” from Hyde Park combines high speed and high sensitivity in the reliable detection of very small objects and edges. This sensor series has fixed sensing windows as small as 3 mm (0.125") within sensing ranges up to 63.5 mm (2.5"). The sensor’s advanced ultrasonic technology, the world’s finest, allows for a deadband as short as 38.1 mm (1.5"), resulting in a quicker decay of “cross talk” and the capability of closer object detection. Another benefit of the technology is revealed in a sampling rate of 0.5 ms, 2000 samples per second and the detection of small reflective surfaces moving past the sensor at 400 inches per second.

For sensing applications requiring connection to a **DeviceNet** network, the flat-profile models in this series are available with this capability as an optional selection.

By virtue of its very high gain and speed, the SM607 noncontact sensor offers reliable detection of objects as small as 0.076 mm (0.003") thick or .0127 mm (0.005") diameter regardless of material, color, or shape. These include items such as thin wires, threads, floss, filaments, electrical connections, fine glue beads on box tops, bag seams, and clear optical extrusions. The high gain and speed work together to create a new edge detection system that can be used on high-speed container lines in detecting tamper-proof safety seals, labels, and caps. Other applications include detecting paper and film edges, tape on packages, web edges, bag seams, and wherever there’s a need to upgrade a metal prox function. The sensors detect all materials, transparent or opaque, liquid or solid.

With protection ratings of NEMA 4X (indoor use only) and IP67, these sensors are impervious to changing light conditions, colors, noise, dust, 100% humidity, caustic chemicals, and other hostile environments. They are resistant to most acids and bases, including most food products. The sensing transducer is made of silicone rubber and the sensors are CE certified. Easy to install, the sensors are available in three different housing styles.

The 18 mm barrel housing sensors are available in either ULTEM® plastic (standard) or SS303 stainless steel. The

- **Fast response - 0.5 ms sampling rate**
- **Fixed sensing window**
- **Self-contained, 18 mm barrel or flat-profile housing styles**
- **Ideal for the precise detection of thin edges, as in labels and tamper-proof seals**
- **Field programmable capability in 18 mm and flat-profile models**
- **DeviceNet Capability available in flat-profile models**
- **CE certified**

“flat-profile” housing sensors are available only in ULTEM® plastic. With all SUPERPROX® sensors, cable and connector styles are available.

Operating on 12 to 24 VDC, these 500 kHz sensors are equipped with sinking type (NPN) and sourcing type (PNP) outputs, a green LED to indicate power “on” and an amber LED to indicate when the object is detected within the fixed window.

The Model SM607 barrel and

flat-profile-style proximity sensors are today's answer for very small object detection and improved productivity throughout the plant.

Operation

The Model SM607 series is a self-contained, pulse-echo device that both transmits and receives sonic energy over a sensing range of up to 51 mm (2"). These sensors use the latest ultrasonic technology with a discriminating microprocessor that allows the sensor to ignore all surrounding sonic interference and detect only the designated object. An object is detected when it is at or within the fixed sensing window.

How does it work?

During setup and operation, these SM607 series sensors continually and accurately measure the elapsed time of every pulse echo reception between each pulse transmission. The transmitted pulse begins a time clock to register the elapsed times for the received pulse echoes. Given the elapsed time, the sensor software calculates the distance traveled out to the object and back to the sensor, using the formula, $D = TV_s/2$, where: D = distance from the sensor to the object; T = elapsed time between the pulse transmission and its echo receptions; V_s = the velocity of sound, approximately 1100 feet per second.

During operation, the calculated distance (D) between the sensor and the object is compared to the distances between the sensor and the fixed window limits. These limits are shown in the illustration as Dwi and Dwo. If D is at or within the fixed window limits, an output change takes place and remains unchanged until the echo either does not return or it returns from outside the fixed window limits. As shown below, Hyde Park offers normally open (N.O.) or normally closed (N.C.) (sinking and sourcing) output models available for discrete

Model Reference Guide - SM607 Series

Use the guide below to ensure the correct model number is specified for the application. Please note that not all sensor model combinations are available.

EXAMPLE MODEL:

Ultrasonic Miniature Proximity Series

Power/Connection Type

0...12 to 24 VDC / cable style

5...12 to 24 VDC / "micro" connector style

Sensing Function

7...Proximity Style - no on/off delay

Design Level

Sensing Range

2...51 mm (2")

A...38.1 mm (1.5") – label edge only

Sensing Window

02...3 mm (0.125")

04...6 mm (0.25")

08...13 mm (0.5")

Functionality

00...Small object/N.O. outputs

10...Small object/N.C. outputs

01...Straight label edge/N.O. outputs

02...Circular label edge/N.O. outputs

11...Straight label edge/N.C. outputs

12...Circular label edge/N.C. outputs

Options

Contact factory for available options

Housing Types

...No letter indicates standard ULTEM® plastic - 18 mm barrel housing

FP...ULTEM® flat-profile housing

SM6 0 7 A - 2 08 - 00 S

on/off sensing applications.

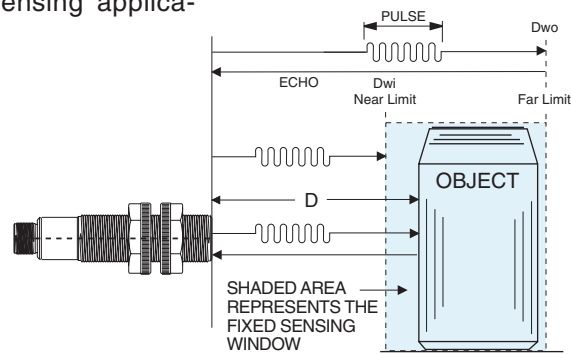

Normally Open Output

The sensor output is "On" with the object in the fixed sensing window.

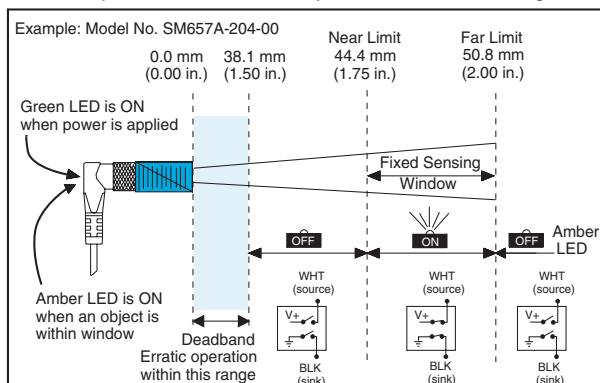

Normally Closed Output

The sensor output is "Off" with the object in the fixed sensing window.

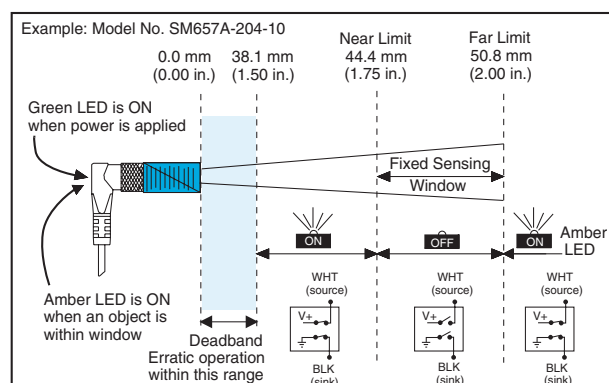

Mounting

The Model SM607 series sensors should be mounted in brackets that allow them to be adjusted for proper alignment. Hyde Park offers the Model AC226 stainless and polyamide conveyor-rail clamp/bracket set, Model AC227 large, right-angle, stainless mounting bracket, Model AC228 small, right-angle, stainless, mounting bracket, Model AC231 straight, stainless, mounting bracket and Model AC232s-shaped, stainless, mounting bracket which are illustrated, with dimensions, on Pages 4-104 and 4-105.

S...SS303 stainless steel - 18 mm barrel housing

NOTE: Contact the factory for DeviceNet communications capability in the flat-profile models

*ULTEM® is a registered trademark of The General Electric Company.

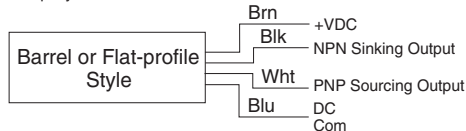

Electrical Wiring

Regardless of model style, the wiring

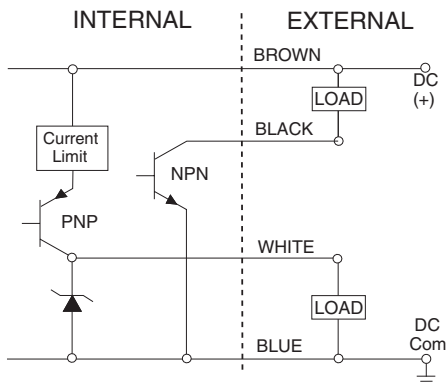

and conductor colors for the Model SM607 series sensors are the same.

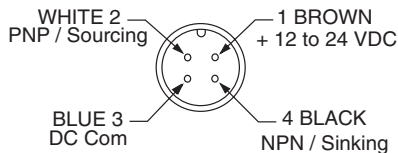

Dimensions

Barrel Cable Style

(ULTEM® plastic and stainless steel)
SM607A-XXX-XX,
SM607A-XXX-XXS

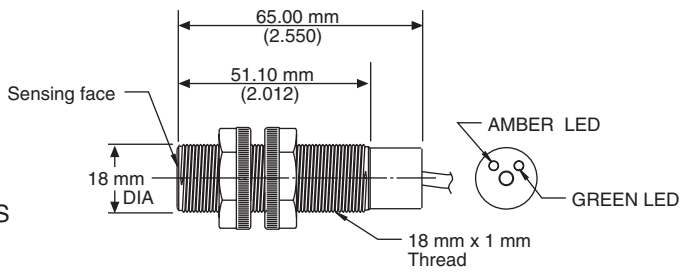

Barrel Connector Style

(ULTEM® plastic and stainless steel)
SM657A-XXX-XX,
SM657A-XXX-XXS

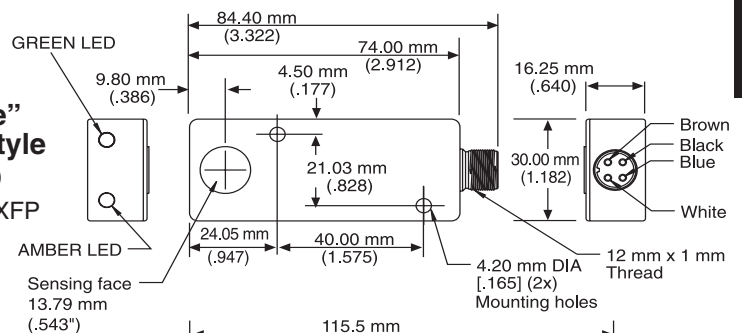
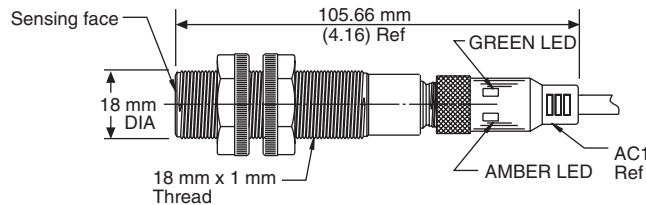
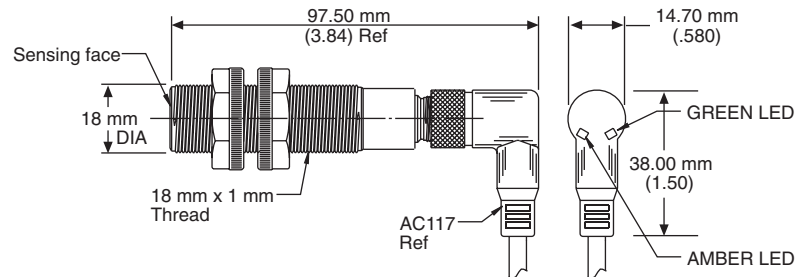
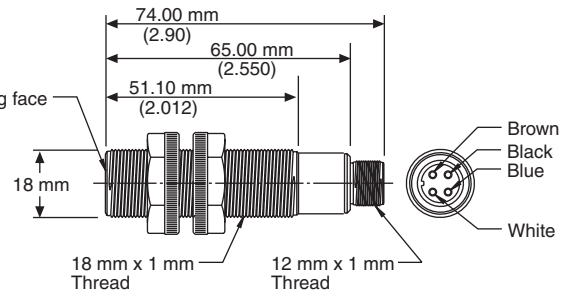

"Flat-profile" Connector Style

(ULTEM® plastic)
SM657A-XXX-XXFP

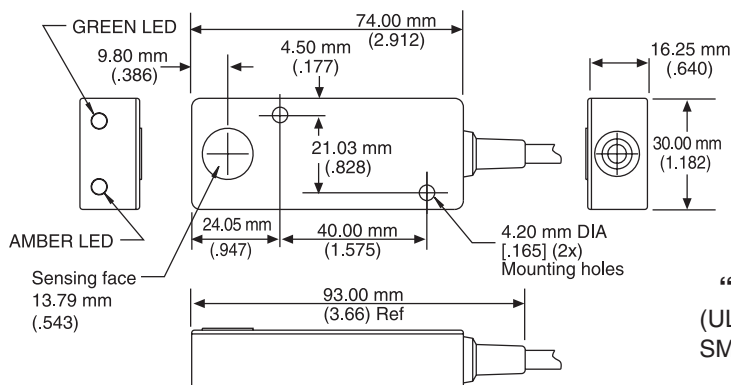

"Flat-profile" Cable Style

(ULTEM® plastic)
SM607A-XXX-XXFP

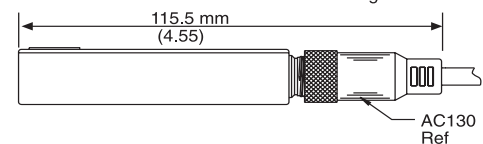

Mounting Accessories

AC117 Right-angle, M12 micro, 4-conductor, connector/cable assembly, 5 m (16'), with built-in LEDs (for barrel connector-style sensors)

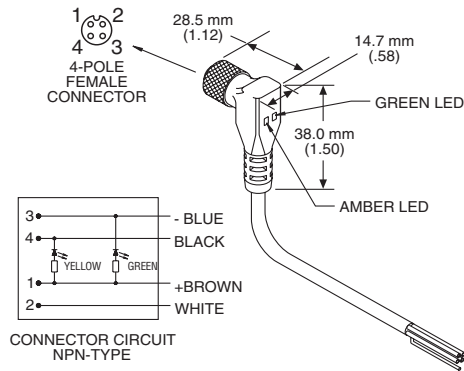

AC127 Straight, M12 micro, 4-conductor, connector/cable assembly, 5 m (16'), with built-in LEDs (for barrel connector-style sensors)

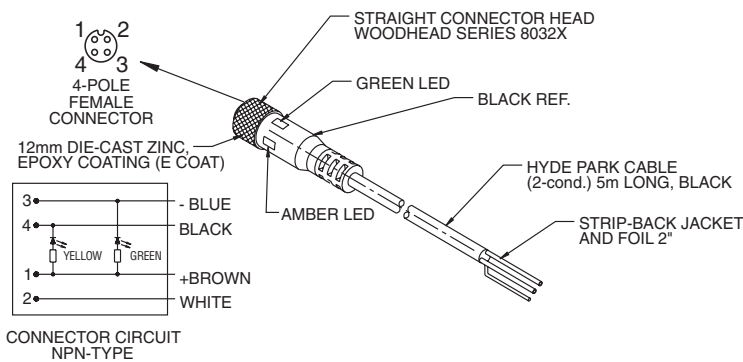

AC130 Straight, M12 micro, 4-conductor, connector/cable assembly, 5 m (16') (for flat-profile connector-style sensors)

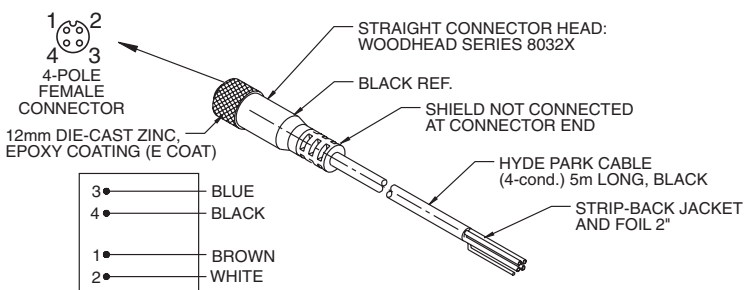

AC226 Stainless and polyamide conveyor-rail clamp/bracket set (for 18 mm barrel sensors)

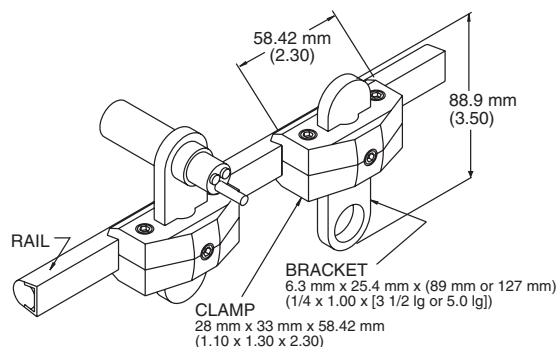

AC227 Large, right-angle, stainless, mounting bracket (for 18 mm barrel sensors)

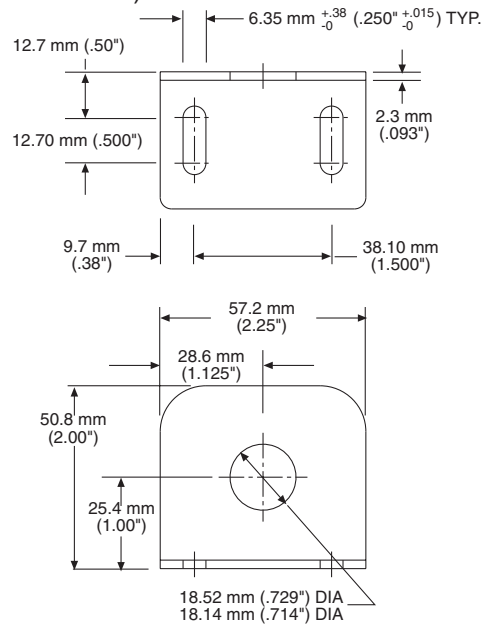

AC228 Small, right-angle, stainless, mounting bracket (for 18 mm barrel sensors)

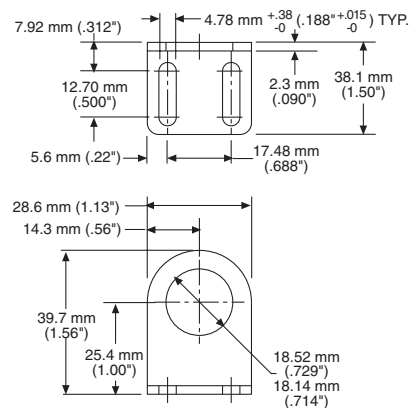

AC231 Straight, stainless mounting bracket (for flat-profile sensors)

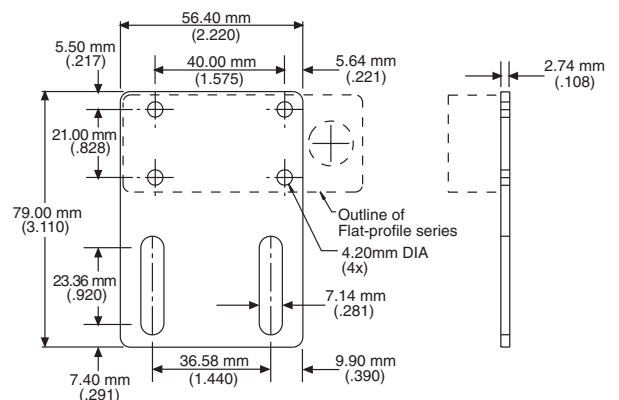

AC232 S-shaped, stainless mounting bracket (for flat-profile sensors)

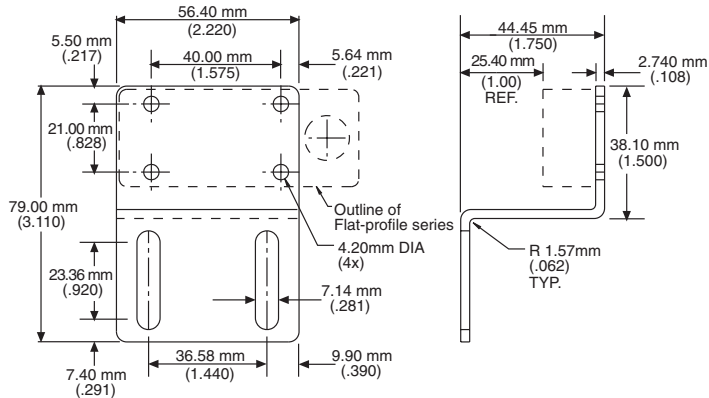

AC241 Steel/black oxide, 45° angle, label edge mounting bracket used with SUPERPROX SM6X7A-A08-01FP or SM6X7A-A08-11FP flat-profile label sensors

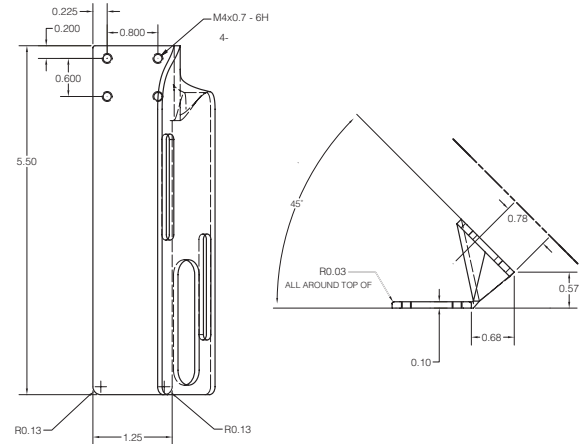

Outputs

NPN Sinking and PNP Sourcing Connector Style Pin Assignments

General Specifications

Sensing

- Ranges: Up to 51 mm (2")
- Spans: From 3.18 mm (1/8") to 38.1 mm (1.5")
- Window Position, Initial Accuracy: ± 1.59 mm (0.062")
- Window Position Repeatability: ± 0.69 mm (0.027")
- Detection Benchmarks: 0.076 mm (0.003") width at a distance of 51 mm (2")
- Sonic Frequency: 500kHz
- Sonic Cone Angle: 7° (see beam plots, page 4-72)

Power Requirements

- Supply Voltage: 12 to 24 VDC ± 10%, regulated supply
- Current Consumption: 70 mA max. (excluding load)
- Power Consumption: 1.7 W max. (excluding load)

Output

- NPN Sinking: 0 to 30 V, 100 mA max.
- The sinking output is "off" when the sensor is not detecting an object (N.O.)
- PNP Sourcing: 0 to 30 V, 1 A max.
- The sourcing output is "off" when the sensor is not detecting an object (N.O.)

Response Time

- "On" 0.5 ms, "Off" 0.5 ms

Indicators

- Green LED: power "on"
- Amber LED: "on" if object is detected within the window, regardless of output polarity (N.O./N.C.) style. Connector model using cable with built-in LEDs: "on" if NPN output is low.

Connections

- Cable Style Models:

- 24 AWG, foil shield, lead-free, PVC jacket, 4-conductor, 3 meters (10') long
- Connector Style Models: 24 AWG, foil shield, lead-free, PVC jacket 4-conductor, right angle "micro" style

Protection

- Power Supply: current-limited over-voltage, ESD, reverse polarity
- Outputs: current-limited over-voltage, ESD, over-current.

Environmental

- Operating Temperature Range: 0° to 60°C @ 12 VDC supply, 0° to 50°C @ 24 VDC supply
- Storage Temperature Range: -40° to 100°C (-40° to 212°F)
- Operating Humidity: 100%
- Protection Ratings: NEMA 4X (indoor use only), IP67
- Chemical Resistance: Resists most acids and bases, including most food products.

Agency Approvals

- CE Mark: CE conformity is declared to: EN61326:1997 (annex A, industrial) including amendment A1:1998. EN55011 Group1 Class A. Declaration of Conformity available upon request

Construction

- Dimensions: Barrel Cable Model: 18 mm dia. x 1 mm threaded housing x 65 mm (2.55") long Connector Model: 18 mm dia. x 1 mm threaded housing x 102 mm (4") long Flat-profile Cable Model: 30 mm (1.182") H x 16.25 mm (0.640") W x 93 mm (3.66") L Connector Model: 30 mm (1.182") H x 16.25 mm (0.640") W x 84.4 mm (3.322") L Housing: Shock and vibration resistant Case: ULTEM® plastic - (FDA Approved) (SS303 stainless steel available only in 18 mm barrel-style) Transducer Face: Silicone rubber - gray

- Sensor Cable: Lead-free PVC jacket, black (Model AC117)
- LED: Polycarbonate

* ULTEM® is a registered trademark of The General Electric Co.

Accessories

18 mm Barrel Mounting Hardware and Cables

- Model AC117**, Right-angle, M12 micro, 4-conductor, connector/cable assembly, 5 m (16') with built-in LED's for barrel connector-style prox sensors
- Model AC127**, Straight, M12 micro, 4-conductor, connector/cable assembly, 5 m (16'), with built-in LED's for barrel connector-style prox sensors
- Model AC226**, Stainless and polyamide conveyor-rail clamp/bracket set
- Model AC227**, Large, right-angle, stainless, mounting bracket
- Model AC228**, Small, right-angle, stainless, mounting bracket

Flat-profile Mounting Hardware and Cables

- Model AC130**, Straight, M12 micro, 4-conductor, connector/cable assembly, 5 m (16'), for flat-profile, connector-style prox sensors
- Model AC231**, Straight, stainless, mounting bracket
- Model AC232**, S-shaped, stainless, mounting bracket AC241 Steel/black oxide, 45° angle, label edge mounting bracket used with SUPERPROX SM6X7A A08-01FP or SM6X7A-A08-11FP flat-profile label sensors
- Model AC241**, Steel/black oxide, 45° angle, label edge mounting bracket used with the SUPERPROX® SM6X7A-A08-01FP or SM6X7A-A08-11FP flat-profile label sensors

See page 7-1 for accessory photos.

SUPERPROX® PROXIMITY SENSORS

Selection Chart

SM607 Series Proximity

Model No.	Power Version		Connector	Connection Style	Sensing		Transducer Materials			
	12-24 VDC	Cable			Range	Window	Silicone*	18mm ULTEM®	18mm stainless	Flat-profile
SM607A-A08-01•	■	■			38.1mm (1.5")	12.7mm (.5")	■	■		
SM607A-A08-01FP•	■	■			38.1mm (1.5")	12.7mm (.5")	■			■
SM607A-A08-01S•	■	■			38.1mm (1.5")	12.7mm (.5")	■		■	
SM607A-A08-02	■	■			38.1mm (1.5")	12.7mm (.5")	■	■		
SM607A-A08-02FP	■	■			38.1mm (1.5")	12.7mm (.5")	■		■	
SM607A-A08-02S	■	■			38.1mm (1.5")	12.7mm (.5")	■		■	
SM607A-202-00	■	■			51mm (2")	3mm (.125")	■	■		
SM607A-202-00FP	■	■			51mm (2")	3mm (.125")	■			■
SM607A-202-00S	■	■			51mm (2")	3mm (.125")	■		■	
SM607A-204-00	■	■			51mm (2")	6mm (.25")	■	■		
SM607A-204-00FP	■	■			51mm (2")	6mm (.25")	■			■
SM607A-204-00S	■	■			51mm (2")	6mm (.25")	■		■	
SM607A-208-00•	■	■			51mm (2")	13mm (.5")	■	■		
SM607A-208-00FP•	■	■			51mm (2")	13mm (.5")	■			■
SM607A-208-00S•	■	■			38.1mm (1.5")	12.7mm (.5")	■		■	
SM657A-A08-01•	■	■			38.1mm (1.5")	12.7mm (.5")	■	■		
SM657A-A08-01FP•	■	■			38.1mm (1.5")	12.7mm (.5")	■			■
SM657A-A08-01S	■	■			38.1mm (1.5")	12.7mm (.5")	■		■	
SM657A-A08-02	■	■			38.1mm (1.5")	12.7mm (.5")	■	■		
SM657A-A08-02FP	■	■			38.1mm (1.5")	12.7mm (.5")	■			■
SM657A-A08-00S	■	■			51mm (2")	13mm (.5")	■		■	
SM657A-202-00	■	■			51mm (2")	3mm (.125")	■	■		
SM657A-202-00FP	■	■			51mm (2")	3mm (.125")	■			■
SM657A-202-00S	■	■			51mm (2")	3mm (.125")	■		■	
SM657A-204-00	■	■			51mm (2")	6mm (.25")	■	■		
SM657A-204-00FP	■	■			51mm (2")	6mm (.25")	■			■
SM657A-204-00S	■	■			51mm (2")	6mm (.25")	■		■	
SM657A-208-00•	■	■			51mm (2")	13mm (.5")	■	■		
SM657A-208-00FP•	■	■			51mm (2")	13mm (.5")	■			■
SM657A-208-00S•	■	■			51mm (2")	13mm (.5")	■		■	

• = Most commonly stocked sensors

* = See definition in Sensing Terms.

All possible sensor configurations are not listed here.