

- **General Info**
- **Temperature**
- **Pressure**
- **Flow**
- **Speed**
- **Weighing**
- **Process**

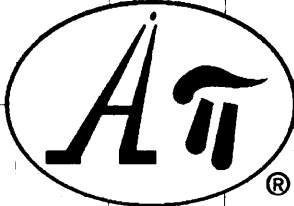

Absolute Process Instruments, Inc.

Manufacturer of Quality Signal Conditioners Transmitters & Isolators

Application Notes

What is a Ground Loop

In a process control loop, a ground loop circuit can develop when each device's ground is tied to a different earth potential thereby allowing current to flow between the grounds by way of the process loop (Figure 1). Ground loops cause problems by adding or subtracting current or voltage from the process loop. This addition and/or subtraction causes the receiving device to be unable to differentiate between the wanted and unwanted signals and thus can't accurately reflect actual process signals.

The probability of multiple grounds and ground loops being established is especially high when new programmable logic controllers (PLCs) or distributed control systems (DCSs) are installed. With so many conditions within a facility referenced to ground, the likelihood of establishing more than one ground point is great. Thus, if an instrumentation system seems to be acting strangely or erratically, and the problem seems to point toward ground loops, the chore of eliminating all unintended ground connections becomes overwhelming.

Keep in mind that eliminating ground loops just isn't feasible for some instruments, such as thermocouples and some analyzers, because they require a ground to obtain accurate rate measurements. Also, some instruments must be grounded to ensure personnel safety. When ground loops can't be eliminated the solution lies in the use of signal isolators. These devices break the galvanic path (DC continuity) between all grounds while allowing the analog signal to continue through the loop. An isolator also can eliminate the electrical noise of AC continuity (common mode voltage).

Signal isolators can use numerous techniques to achieve their function but the best signal isolators usually employ optical isolators (Figure 2). Regardless of the isolation method used, an isolator must provide input, output, and power isolation. If this three-way isolation is not provided, then an additional ground loop can develop between the isolator's power supply and the process input and/or output signal.

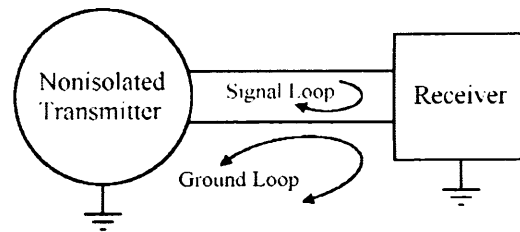

Figure 1. Ground loops may develop with nonisolated transmitters and receivers, resulting in inaccuracy and unreliability.

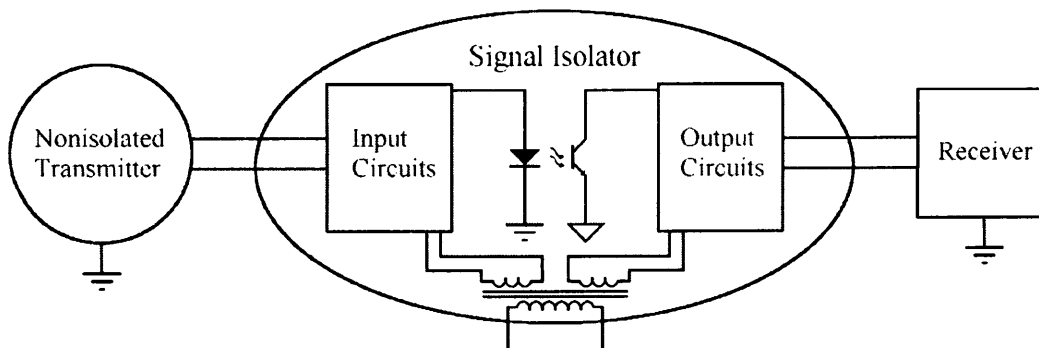

Figure 2. A signal isolator in the process loop blocks ground current to restore signal accuracy and reliability.



Michael J. Trask
 P.O. Box 1778 (29652-1778)
 414 West Poinsett Street
 Greer, SC 29650
 864-848-3993 FX: 864-848-9569
www.traskinstrumentation.com

Did You Know...?

A common design error is to "save money" by selecting non-isolated transmitters. It costs far more to correct the problem later.

When in doubt - isolate!