



DIGITAL LASER SENSOR

LS SERIES



Easy and Precise!

User-friendly, high precision laser sensing!

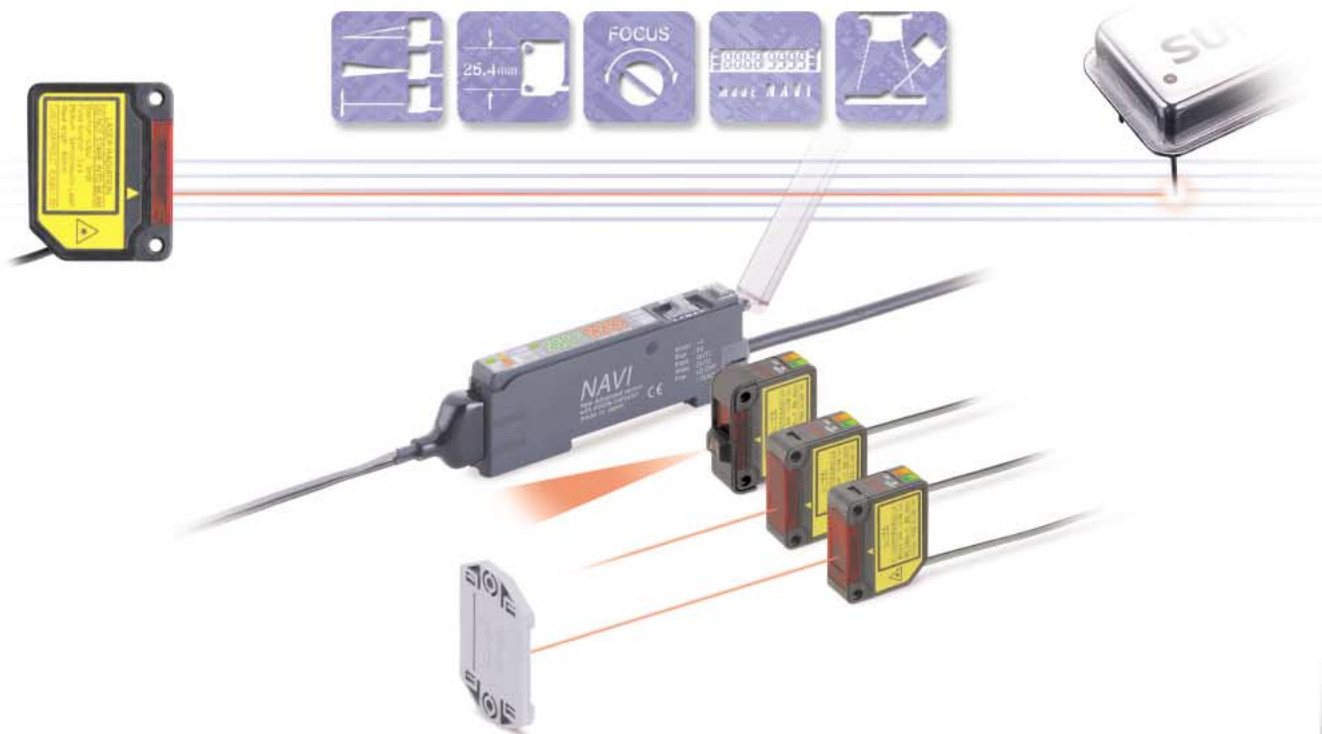

Announcing the new long sensing range coaxial retroreflective type with a 30 m **98.425 ft** sensing range, and the spot reflective type with Class 1 level of safety

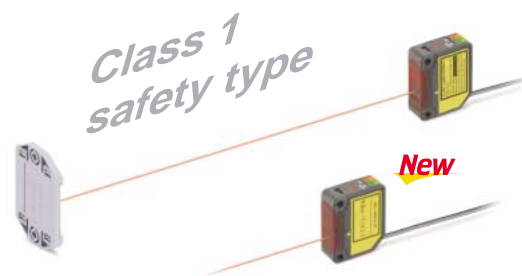
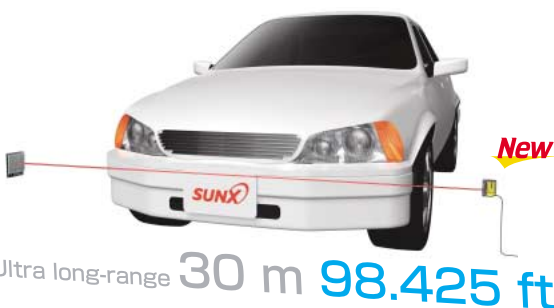

Easy Sensing

We offer 6 types of laser sensor heads for various applications.

The LS-H□F (-A) FDA standard conforming type is also available for all types.

Long sensing range line reflective type

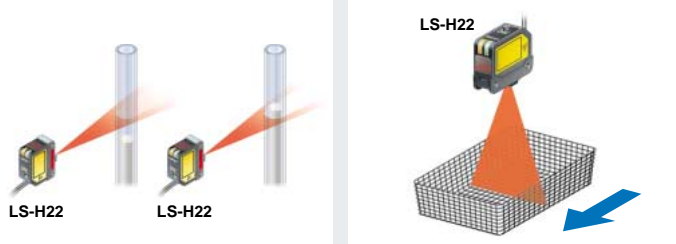

Its linear sensing area enables more stable detection of objects with complex shapes.

A line width of approx. 100 mm
3.937 in (typical) at a 500 mm
19.685 in sensing range

Note: The applications given in this catalog are examples for reference only. Stable sensing may not be possible under certain setup conditions and environmental conditions, so be sure to check the actual equipment before use.

A line width of approx. 200 mm
7.874 in (typical) at a 1,000 mm
39.370 in sensing range



Long sensing range line reflective type LS-H22

※ LS-H22 is the model No. for LS-H21 long sensing range spot reflective type sensor head combined with the LS-MR1 lens attachment for line reflective type, hence LS-H21 appears on the sensor head itself.



New
Long sensing range coaxial retroreflective type LS-H92



Coaxial retroreflective type LS-H91



Coaxial retroreflective type LS-H91-A **Class 1 type**

※A spot diameter of approx.
φ 1 mm φ0.039 in at a 1 m
3.281 ft sensing range

Coaxial retroreflective type



Ultra long-range sensing up to 30 m 98.425 ft is possible. Beam axis alignment is easy using the bright spot light.



This is a coaxial retroreflective sensor with a spot diameter of approx. φ 1 mm φ0.039 in (at a 1 m 3.281 ft sensing range), so it can measure amounts remaining on sheet rolls with high precision.

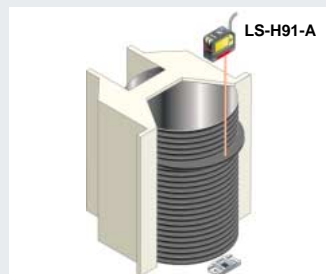

The first visible light spot for a Class 1 type (FDA standards) (as of October 2004 and based on research conducted by SUNX) . This makes beam axis alignment much easier.

※The spot diameter is a typical example. The measurement values given here were determined with a center light intensity of 1/e² (13.5%).

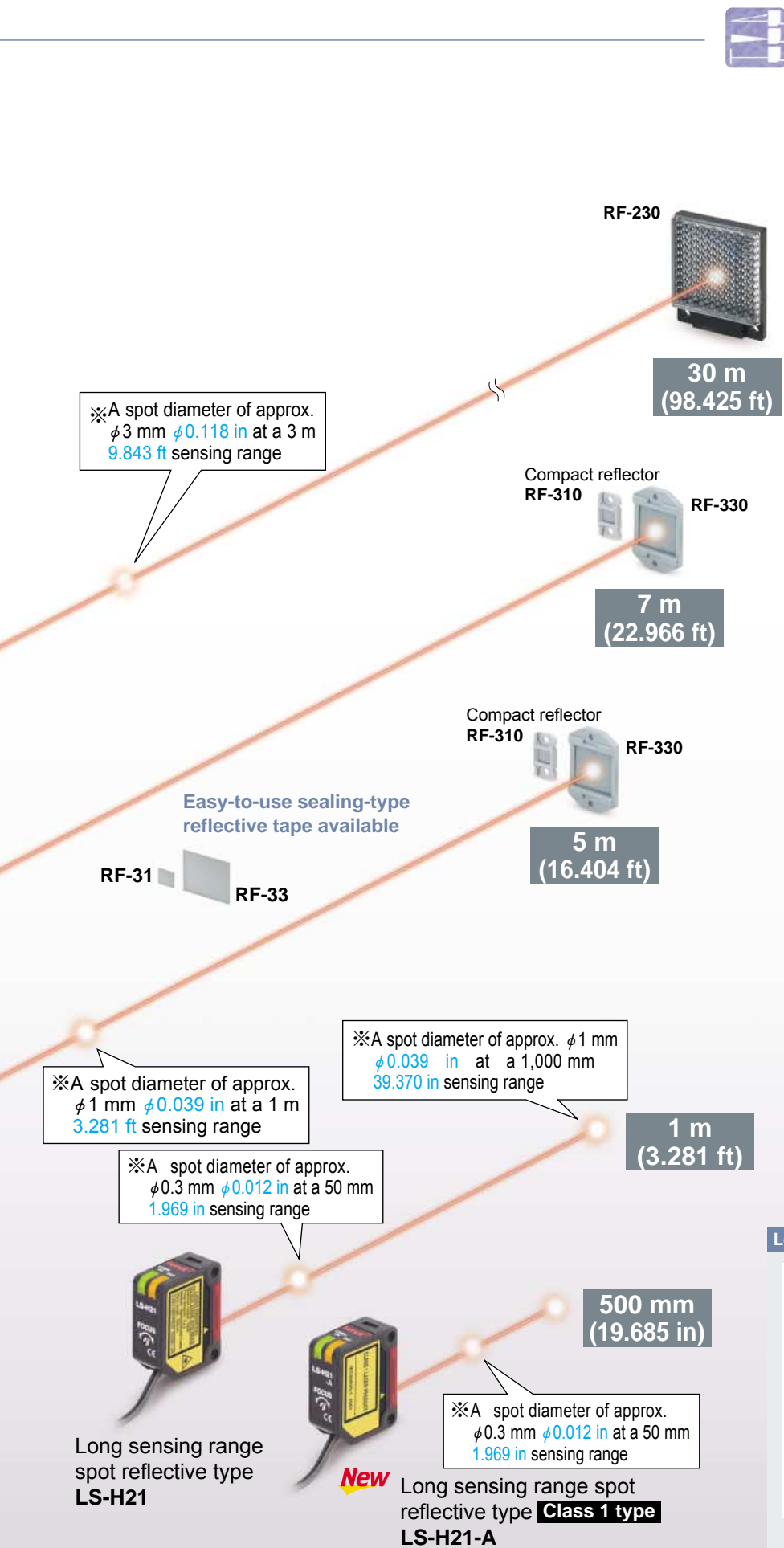

Easy 1 Installation



Easy installation

P3 ▶

We designed 3 types of sensor heads about the same size as general purpose photoelectric sensors.

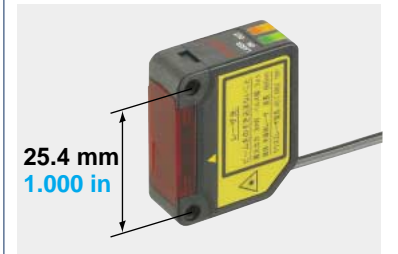

Easy 2 Adjustment



Easy adjustment

P4 ▶

Spot shape adjustment made simple.



Easy 3 Operation



Easy operation

P5 ▶

Uses the popular MODE NAVI feature found in fiber sensors ensuring both multi-functionality and superior operability.



Easy 4 High Performance



Complex functions made simple

P7 ▶

Handy, on-site functionality.

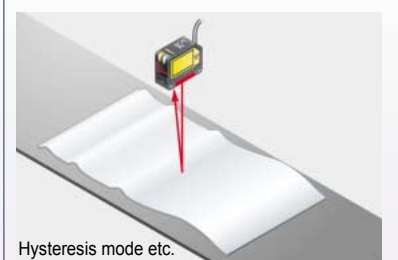

Hysteresis mode etc.

Long sensing range spot reflective type

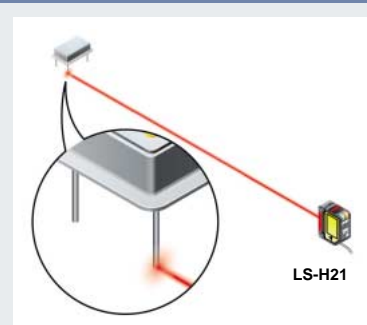

Because its spot shape can be adjusted in accordance with the object, it can be easily set to detect even the minutest object from a remote location.



Easy installation

Sensor heads are designed approximately the same size as general purpose photoelectric sensors and the mounting method is identical. (Long sensing range spot reflective / Long sensing range line reflective / Coaxial retroreflective types)

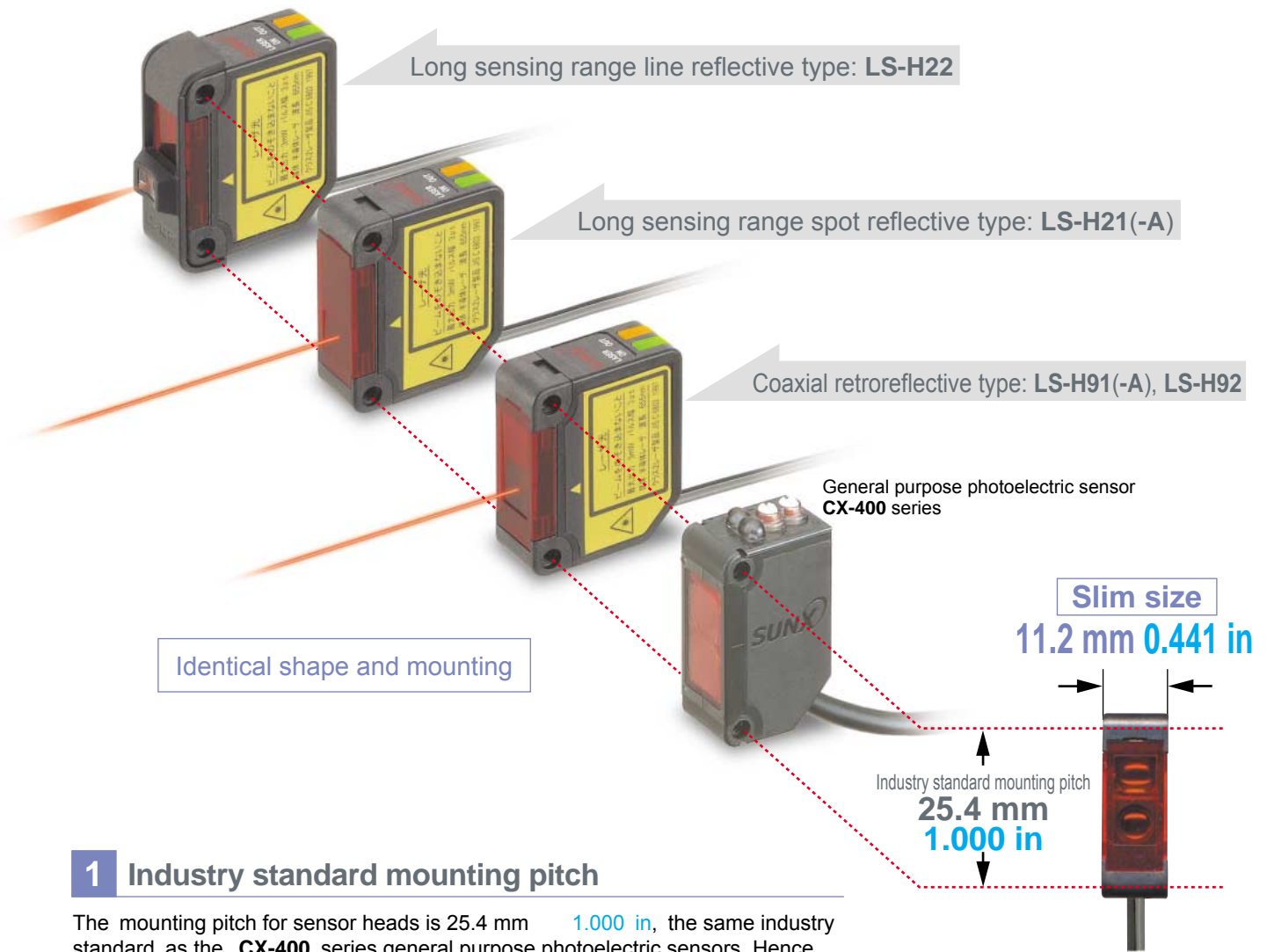

1 Industry standard mounting pitch

The mounting pitch for sensor heads is 25.4 mm 1.000 in, the same industry standard as the **CX-400** series general purpose photoelectric sensors. Hence, existing mounting brackets can be used even when replacing general purpose sensors with laser sensors.

2 Assorted mounting brackets available

Because their mounting is compatible with general purpose photoelectric sensors, the mounting brackets for the general purpose photoelectric sensors and the universal sensor mounting stand can be used.

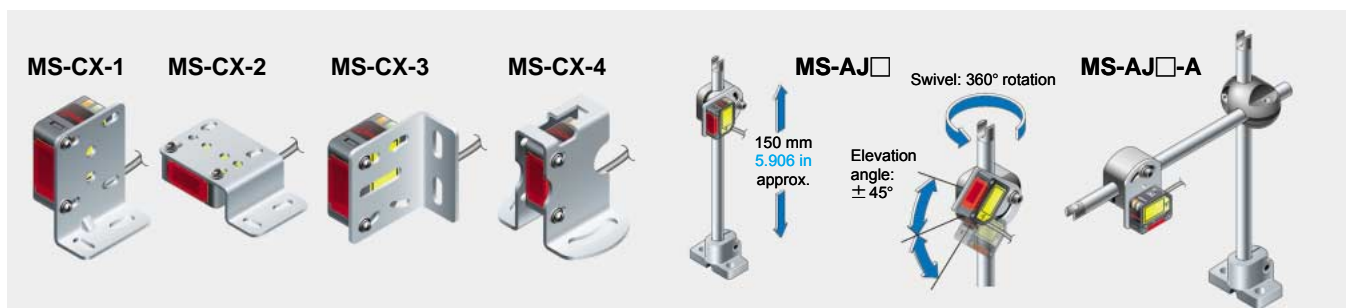

Easy adjustment | Spot shape adjustment made simple.

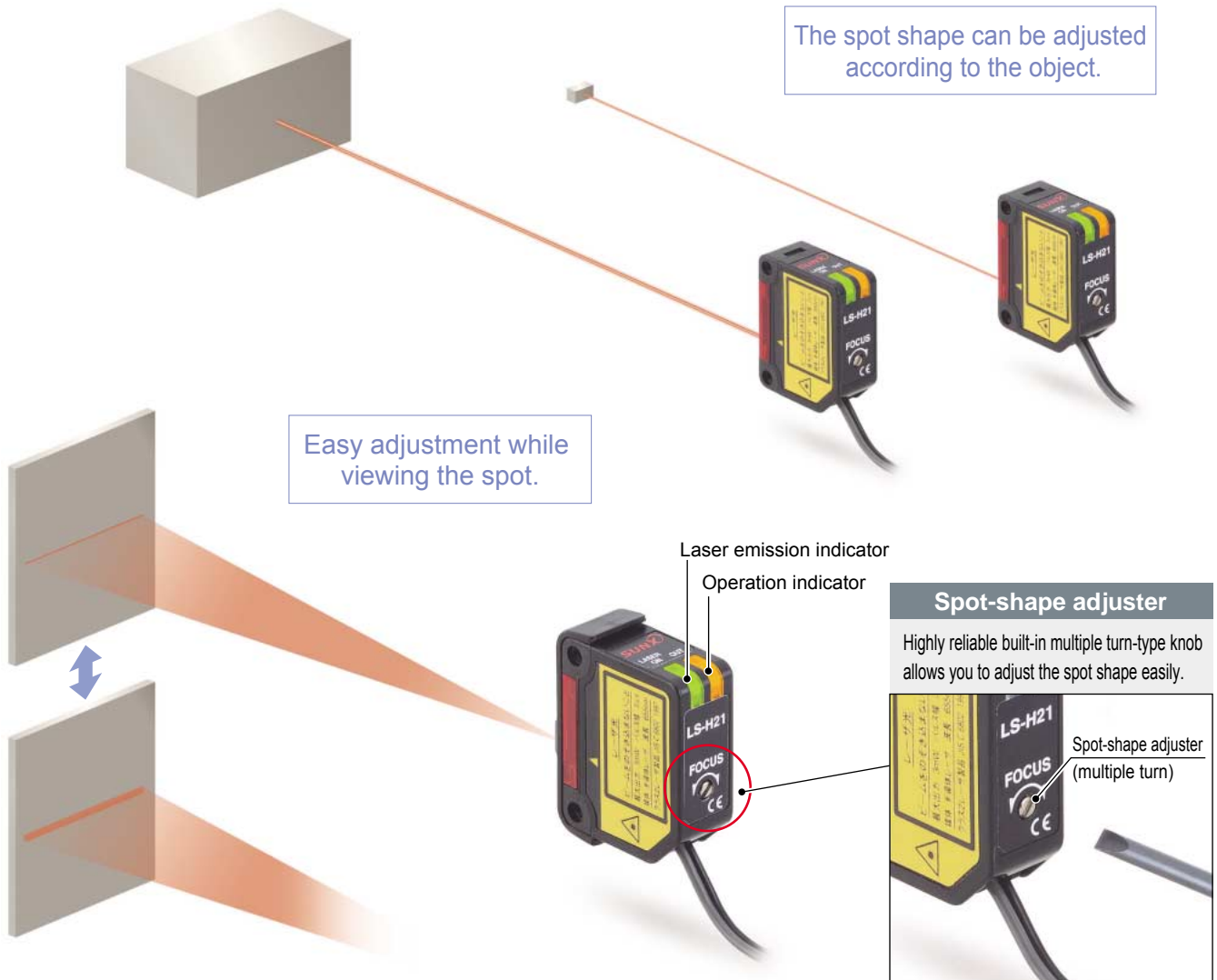

1 Spot shape adjustment possible LS-H21, LS-H22

The long sensing range spot reflective type and long sensing range line reflective type have a built-in spot-shape adjuster that enables spot shape adjustment according to the object for optimal setting.

2 Easy and accurate adjustments LS-H21, LS-H22

A spot-size adjuster is built into the back of the sensor head allowing the user to adjust the sensor easily while viewing the spot. The adjuster is adjustable with a screwdriver to avoid accidents during maintenance or any other time the sensors are handled.



Easy operation

Uses MODE NAVI, highly praised in the **FX-300** series digital fiber sensors. Besides featuring a dual display screen that shows the incident light intensity and threshold value simultaneously, it also offers both multi-functionality and superior operability.

10 mm 0.394 in thickness



Threshold value setting display
Green LED, 4 digits
(Max. display: 9999)

1 Easy setting, dual display

Equipped with 2 large 4-digit digital displays. While checking the current incident light intensity (red display), the optimal threshold value (green display) can be set easily.

2 Maximum display of 9999

The counter display's subdivide range of up to 9999 enables you to make extremely accurate adjustments. The result is more stable sensing that ensures that even the minutest variation in transparent objects is detected.



3 Easy to view guide display

Setting items understood at a glance.

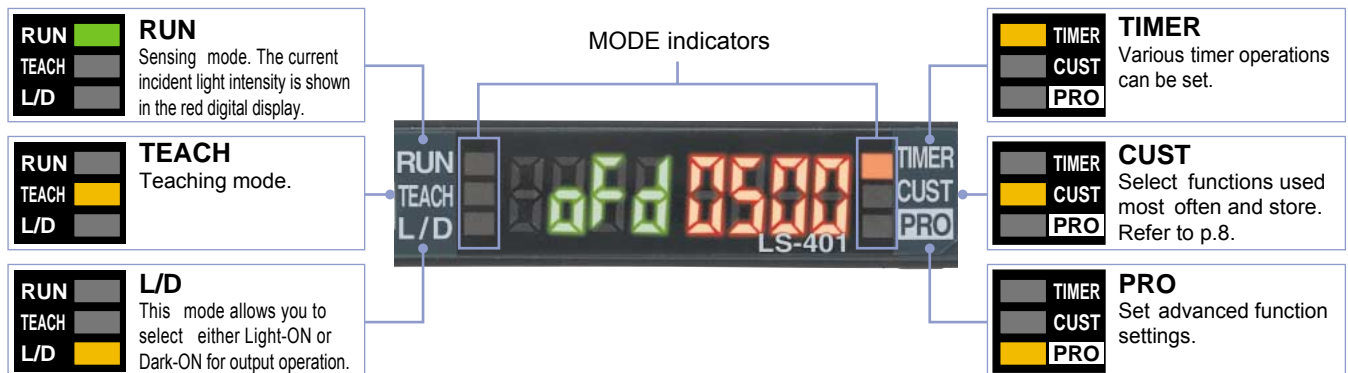

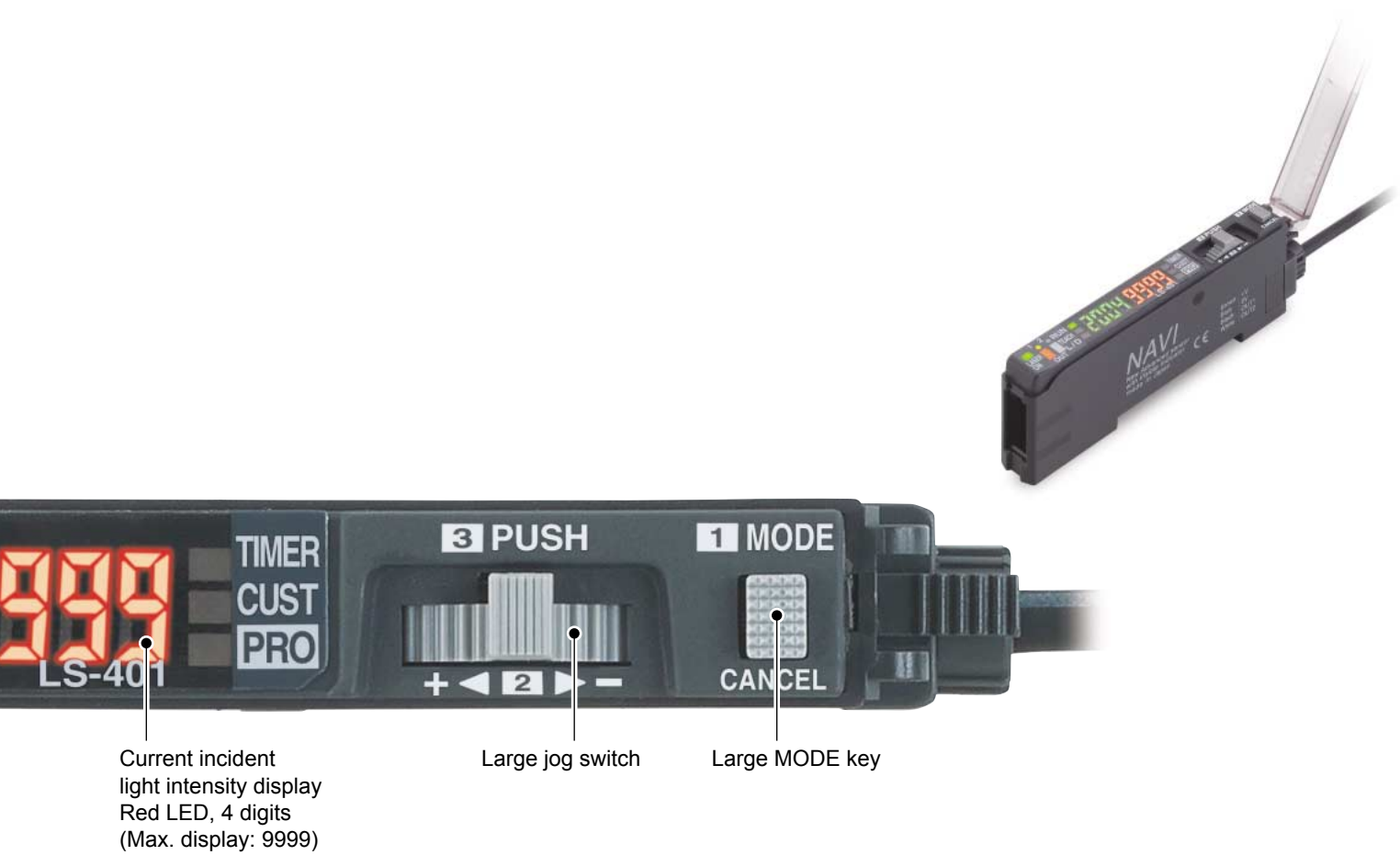

Current incident light intensity display
Red LED, 4 digits
(Max. display: 9999)

Large jog switch

Large MODE key

4 2 switches enable simple operation

Only two switches, the large MODE key and the large jog switch, are required for operation.



1 MODE Pressing the switch selects or cancels the operating mode

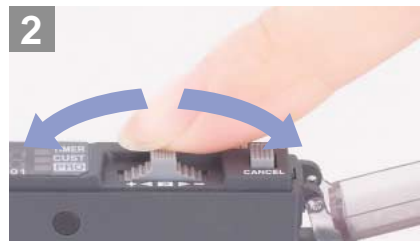

2 Moving the switch from side to side allows items to be selected



3 PUSH Pressing the switch then confirms the selected setting

5 Wiring and space savings

The quick-connection cables enable reductions in wiring (connector type). The connections and man-hours for the relay terminal setup can be reduced and valuable space saved. Also, LS series sensors can be connected side-by-side with FX-300 series fiber sensors.

Fiber sensor FX-300 series



Up to 16 units can be connected together

Note: Because the transmission method varies depending on the amplifiers, check the instruction manual for the amplifiers when connecting them.

6 Cable type allows external input

The LS-401-C2 cable-type amplifier is equipped with external input wires (5-core). It is ideal for using the laser sensors in places when external teaching or laser light emission halting is to be carried out, or when using separately.

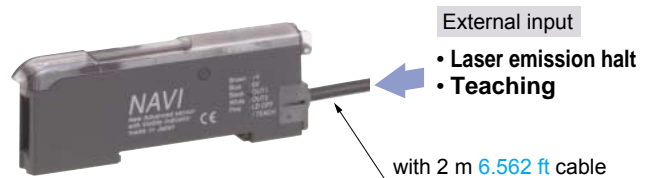



Easy to use complex functions

Handy functions made simple for easy, on-site use.

1 Accurately sense the minutest variations (M.G.S. function)

New proposal

When sensing at close range or when the target objects are transparent or minute, adjust the sensor receiving sensitivity to one of 3 levels for the optimal setting. In addition, changing the receiving sensitivity will not effect the response time.

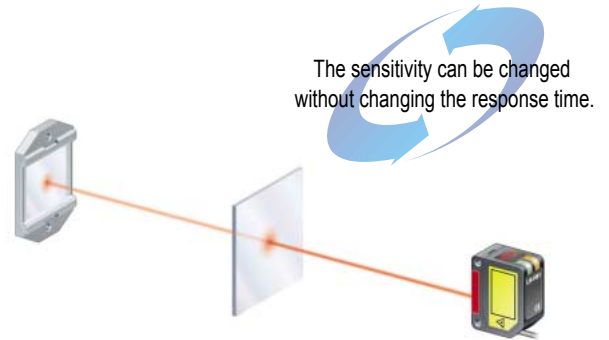
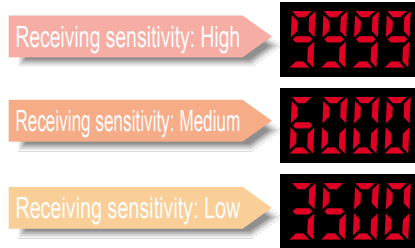

2 4 new modes enabling wide array of sensing

Hysteresis mode

New proposal

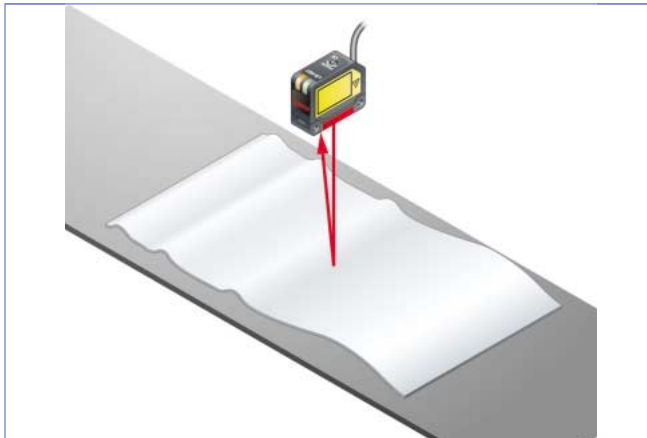

By adjusting the hysteresis, convexo-concave parts of uneven objects can be cancelled enabling more stable sensing.

Window comparator mode

New proposal

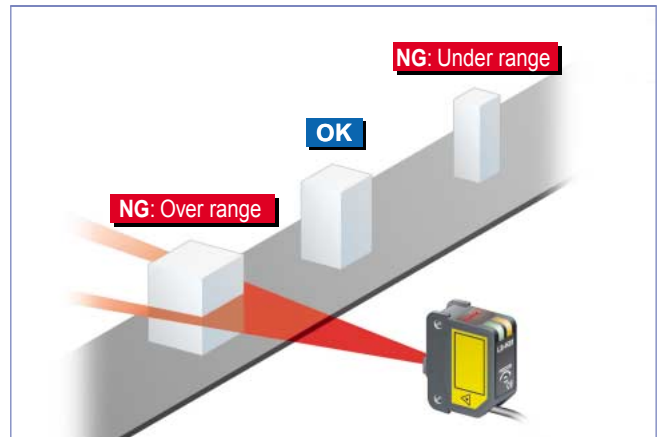

The sensor judges any object outside the range of incident light intensity established by two set threshold values.

2 independent output modes

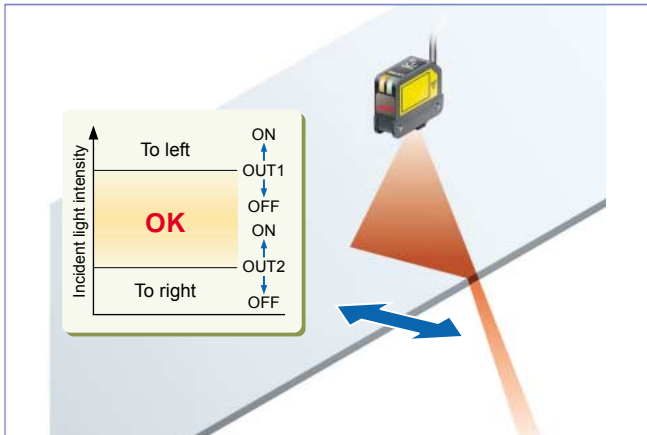

By combining two outputs, wide array of control is possible, allowing you to detect meandering objects, for example.

Differential sensing mode



Only rapid changes in light received are detected, which enable the edge of glass, etc. to be detected accurately. Optimal for positioning.

3 MODE NAVI customized function

Because one of frequently used functions (response time, M.G.S. function, data bank load, emission halt function and D-CODE values) can be stored in CUSTOM mode, the settings are changed easily.

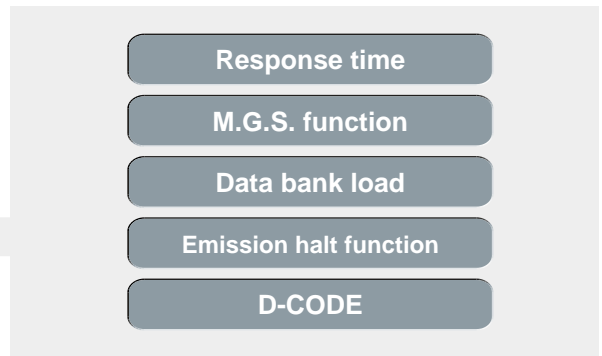
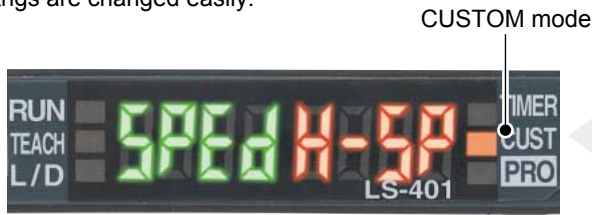

4 Equipped with handy, easy-to-use functions

Emission halt function

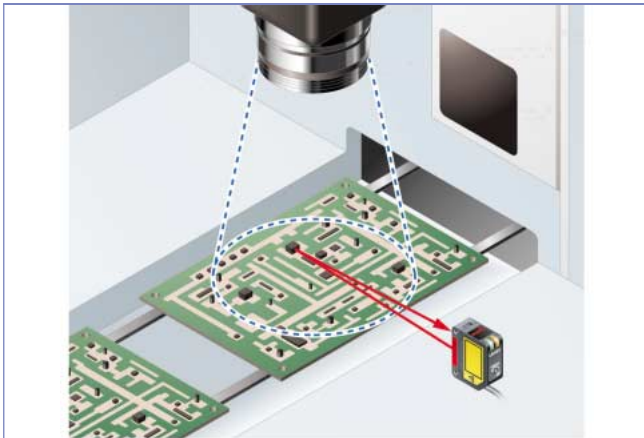

Using the emission halt function, the laser beam can be stopped via external input, e.g. when a spot appears within the visual range of an image processor.

External teaching function

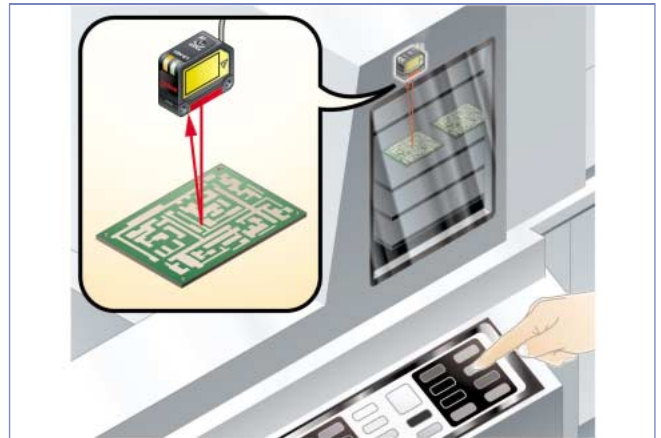

Teaching can be conveniently performed externally for laser sensors installed inside a device.

Interference prevention function

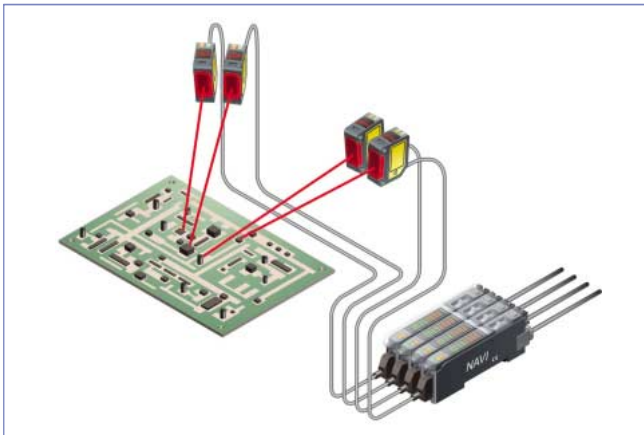

The automatic interference prevention function protects against interference among up to 4 sensors.

Setting conditions viewed at a glance (D-CODE) New proposal

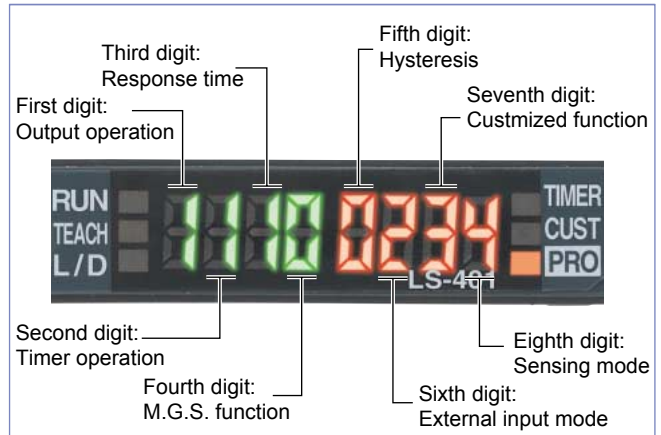

The amplifier setting is shown as an 8-digit code. Handy for remote indications and follow-ups.

ORDER GUIDE

Sensor heads

Type	Appearance	Model No.	Conforming standards	Sensing range	■ : U-LG ■ : STD ■ : FAST ■ : H-SP
Coaxial retroreflective		New LS-H92	JIS / IEC / GB	■ 0.2 to 30 m 0.656 to 98.425 ft (Note 2)	
		New LS-H92F (Note 1)	FDA / IEC / JIS	■ 0.2 to 20 m 0.656 to 65.617 ft (Note 2)	
		LS-H91	JIS / IEC / GB	■ 0.2 to 10 m 0.656 to 32.808 ft (Note 2)	
		LS-H91F (Note 1)	FDA / IEC / JIS	■ 0.2 to 10 m 0.656 to 32.808 ft (Note 2)	
		LS-H91-A	JIS / IEC / GB	■ 0.1 to 7 m 0.328 to 22.966 ft (Note 2)	
		LS-H91F-A (Note 1)	FDA / IEC / JIS	■ 0.1 to 5 m 0.328 to 16.404 ft (Note 2)	
Diffuse reflective	Long sensing range spot reflective		LS-H21	JIS / IEC / GB	■ 30 to 1,000 mm 1.181 to 39.370 in
			LS-H21F (Note 1)	FDA / IEC / JIS	■ 30 to 500 mm 1.181 to 19.685 in
			New LS-H21-A	JIS / IEC / GB	■ 30 to 300 mm 1.181 to 11.811 in
	Long sensing range line reflective		New LS-H21F-A (Note 1)	FDA / IEC / JIS	■ 30 to 150 mm 1.181 to 5.906 in
					■ 30 to 150 mm 1.181 to 5.906 in
					LS-H22 (Note 3)
LS-H22F (Note 1, 3)	FDA / IEC / JIS	■ 30 to 500 mm 1.181 to 19.685 in			

NOTE: Mounting bracket is not supplied with the sensor head. Please select from the range of optional sensor head mounting brackets.

- Notes: 1) This product complies with 21 CFR 1040.10 and 1040.11 Laser Notice No. 50, dated July 26, 2001, issued by CDRH (Center for Devices and Radiological Health) under the FDA (Food and Drug Administration). For details, refer to the Laser Notice No. 50.
- 2) The sensing range is the value for the RF-330 [RF-230 for the LS-H92(F)] reflector. In addition, the sensing range is the possible setting range for the reflector. The sensor can detect an object less than 0.1 m [0.328 ft] [LS-H92(F): 0.2 m 0.656 ft] away. Note that if there are white papers or specular objects near the sensor head, reflected light from these objects may be received. In such cases, use the M.G.S. function of the amplifier unit to change the response time or incident light sensitivity.
- 3) LS-H22(F) is the model No. for LS-H21(F) long sensing range spot reflective type sensor head combined with the LS-MR1 lens attachment for line reflective type sensor head, hence LS-H21(F) appears on the sensor head itself.

5 m 16.404 ft cable length type

5 m 16.404 ft cable length types (Standard: 2 m 6.562 ft) are available. When ordering this type, add '-C5' at the end of the model number.

LS-H91-C5 LS-H91-A-C5 LS-H21-C5 LS-H22-C5

Package without reflector



The LS-H91(F), LS-H91(F)-A and LS-H92(F) are also available without the reflector (RF-330 or RF-230). When ordering this type, add '-Y' at the end of the model number.

LS-H92-Y LS-H92F-Y LS-H91-Y LS-H91F-Y

LS-H91-A-Y LS-H91F-A-Y

ORDER GUIDE

Amplifiers

Type	Appearance	Model No.	Output	Connection method
Connector type		LS-401	NPN open-collector transistor two outputs	Use quick-connection cable (4-core) (optional)
		LS-401P	PNP open-collector transistor two outputs	
Cable type (With external input)		LS-401-C2	NPN open-collector transistor two outputs	2 m 6.562 ft cabtyre cable (5-core) included Cable outer diameter: ϕ 3.7 mm ϕ 0.146 in
		LS-401P-C2	PNP open-collector transistor two outputs	

Quick-connection cables Quick-connection cable is not supplied with the connector type amplifier. Please order it separately.

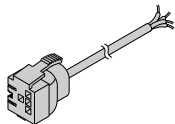
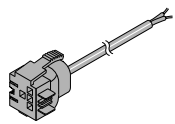
Type	Appearance	Model No.	Description
Main cable (4-core)		CN-74-C1	Length: 1 m 3.281 ft
		CN-74-C2	Length: 2 m 6.562 ft
		CN-74-C5	Length: 5 m 16.404 ft
Sub cable (2-core)		CN-72-C1	Length: 1 m 3.281 ft
		CN-72-C2	Length: 2 m 6.562 ft
		CN-72-C5	Length: 5 m 16.404 ft

End plates End plates are not supplied with the amplifier. Please order separately when the amplifiers are mounted in cascade.

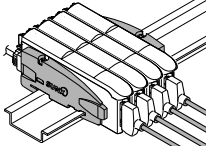
Type	Model No.	Description
	MS-DIN-E	When cascading multiple amplifiers, or when it moves depending on the way it is installed on a DIN rail, these end plates clamp amplifiers into place on both sides. Make sure to use end plates when cascading multiple amplifiers together. Two pcs. per set

Accessories

RF-330 (Reflector)

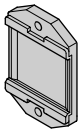

CN-EP1 (Connector for amplifier)
5 pcs. per set (Note)

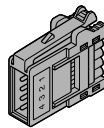

Note: One is attached to each sensor head according to standard.

LS-MR1 (Lens attachment for line reflective type)

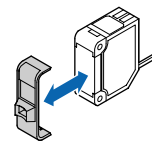

RF-230 (Reflector)



Note: **LS-H92(F)** only

OPTIONS

Designation	Model No.	Description	
Sensor head mounting bracket	MS-CX-1	Foot angled mounting bracket	
	MS-CX-2	Foot biangled mounting bracket Flat mounting possible to avoid obstructions caused by the height of the sensor.	
	MS-CX-3	Back angled mounting bracket	
	MS-CX-4	Protective mounting bracket Protects sensors preventing beam axis displacement due to shocks.	
Universal sensor mounting stand (Note)	MS-AJ1	Horizontal mounting type	Basic assembly
	MS-AJ2	Vertical mounting type	
	MS-AJ1-A	Horizontal mounting type	Lateral arm assembly
	MS-AJ2-A	Vertical mounting type	
Amplifier mounting bracket	MS-DIN-2	Mounting bracket for amplifier	
Reflector mounting bracket	MS-RF23	Mounting bracket for RF-230	
Amplifier protective seal	FX-MB1	10 sets of 2 communication window seals and 1 connector seal Communication window seal: It prevents malfunction due to transmission signal from another amplifier, as well as, prevents effect on another amplifier. Connector seal: It prevents contact of any metal, etc., with the pins of the quick-connection cable.	
Reflector	RF-310	For coaxial retroreflective type Compact reflector	Sensing range (U-LG mode) • LS-H91(F) : 0.1 to 7 m 0.328 to 22.966 ft • LS-H91(F)-A : 0.1 to 5 m 0.328 to 16.404 ft
Reflective tape	RF-33	For coaxial retroreflective type Size: 25.2 × 27.8 × t 0.4 mm 0.992 × 1.094 × t 0.016 in	
	RF-31	For coaxial retroreflective type Size: 9.2 × 9.2 × t 0.4 mm 0.362 × 0.362 × t 0.016 in	

Note: Refer to the 'sensor general catalog 2003-2004' for details of the universal sensor mounting stand.

Sensor head mounting bracket

- **MS-CX-1**
Two M3 (length 12 mm 0.472 in) screws with washers are attached.
- **MS-CX-2**
Two M3 (length 12 mm 0.472 in) screws with washers are attached.

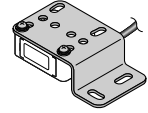
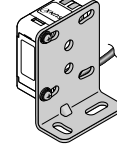

- **MS-CX-3**
Two M3 (length 12 mm 0.472 in) screws with washers are attached.
- **MS-CX-4**
Two M3 (length 12 mm 0.472 in) screws with washers are attached.

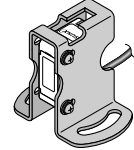
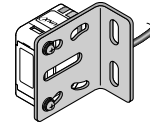

Amplifier mounting bracket

- **MS-DIN-2**

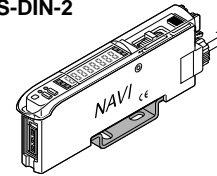

Reflector mounting bracket

- **MS-RF23**

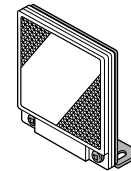

Two M4 (length 10 mm 0.394 in) screws with washers are attached.

Amplifier protective seal

- **FX-MB1**

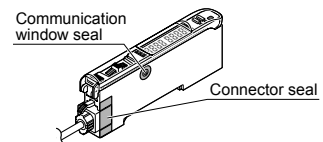

Universal sensor mounting stand

- **MS-AJ1**

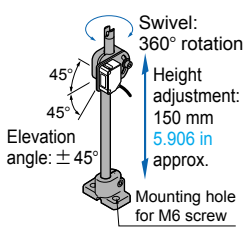

- **MS-AJ1-A**

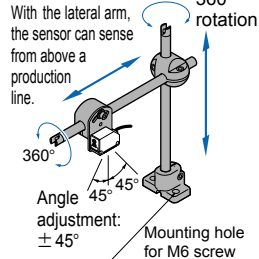

- **MS-AJ2**

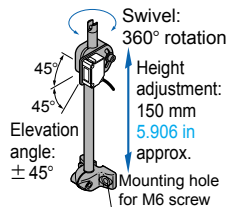

- **MS-AJ2-A**

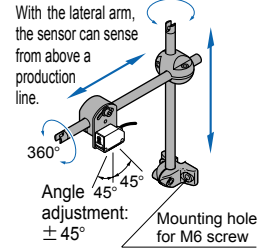

Reflector

- **RF-310**

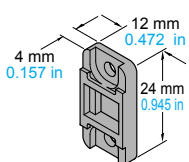

Reflective tape

- **RF-33**

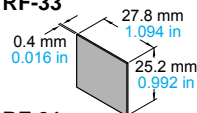

- **RF-31**

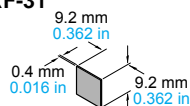

SPECIFICATIONS

Sensor heads

Item	Model No.	Type	Coaxial retroreflective			Diffuse reflective		
			Long sensing range	Class 2	Class 1	Long sensing range spot reflective		Long sensing range line reflective
						Class 2	Class 1	
	IEC / JIS / GB standards conforming type		LS-H92	LS-H91	LS-H91-A	LS-H21	LS-H21-A	LS-H22 (Note 3)
	FDA / IEC / JIS standards conforming type (Note 2)		LS-H92F	LS-H91F	LS-H91F-A	LS-H21F	LS-H21F-A	LS-H22F (Note 3)
Applicable amplifiers			LS-401(P), LS-401(P)-C2					
Sensing range	LONG mode		0.2 to 30 m 0.656 to 98.425 ft (Note 4)	0.1 to 7 m 0.328 to 22.966 ft (Note 4)	0.1 to 5 m 0.328 to 16.404 ft (Note 4)	30 to 1,000 mm 1.181 to 39.370 in	30 to 500 mm 1.181 to 19.685 in	30 to 1,000 mm 1.181 to 39.370 in
	STD mode		0.2 to 20 m 0.656 to 65.617 ft (Note 4)	0.1 to 5 m 0.328 to 16.404 ft (Note 4)	0.1 to 3 m 0.328 to 9.843 ft (Note 4)	30 to 500 mm 1.181 to 19.685 in	30 to 250 mm 1.181 to 9.843 in	30 to 500 mm 1.181 to 19.685 in
	FAST mode		0.2 to 10 m 0.656 to 32.808 ft (Note 4)	0.1 to 3 m 0.328 to 9.843 ft (Note 4)	0.1 to 1 m 0.328 to 3.281 ft (Note 4)	30 to 300 mm 1.181 to 11.811 in	30 to 150 mm 1.181 to 5.906 in	30 to 300 mm 1.181 to 11.811 in
	H-SP mode							
Operation indicator			Orange LED (lights up when the amplifier output is ON)					
Laser emission indicator			Green LED (lights up during laser emission)					
Spot-shape adjuster			_____			Multi-turn adjuster		
Environmental resistance	Ambient temperature	- 10 to + 55 °C + 14 to + 131 °F (No dew condensation or icing allowed), Storage: - 20 to + 70 °C - 4 to + 158 °F						
	Ambient humidity	35 to 85 % RH, Storage: 35 to 85 % RH						
	Ambient illuminance	Incandescent light: 3,000 lx at the light-receiving face						
	Voltage withstandability	1,000 V AC for one min. between all supply terminals connected together and enclosure						
	Insulation resistance	20 MΩ, or more, with 250 V DC megger between all supply terminals connected together and enclosure						
	Vibration resistance	10 to 500 Hz frequency, 1.5 mm 0.059 in amplitude in X, Y and Z directions for two hours each						
	Shock resistance	100 m/s ² acceleration (10 G approx.) in X, Y and Z directions for three times each						
Emitting element	IEC / JIS / GB standards conforming type	Red semiconductor laser, Class 2 (IEC / JIS / GB) (Max. output: 3 mW Peak emission wavelength: 655 nm 0.026 mil)	Red semiconductor laser, Class 1 (IEC / JIS / GB) (Max. output: 1 mW Peak emission wavelength: 655 nm 0.026 mil)	Red semiconductor laser, Class 2 (IEC / JIS / GB) (Max. output: 3 mW Peak emission wavelength: 655 nm 0.026 mil)	Red semiconductor laser, Class 1 (IEC / JIS / GB) (Max. output: 1 mW Peak emission wavelength: 655 nm 0.026 mil)	Red semiconductor laser, Class 2 (IEC / JIS / GB) (Max. output: 3 mW Peak emission wavelength: 655 nm 0.026 mil)	Red semiconductor laser, Class 1 (IEC / JIS / GB) (Max. output: 1 mW Peak emission wavelength: 655 nm 0.026 mil)	Red semiconductor laser, Class 2 (IEC / JIS / GB) (Max. output: 3 mW Peak emission wavelength: 655 nm 0.026 mil)
	FDA / IEC / JIS standards conforming type (Note 2)	Red semiconductor laser, Class 2 (FDA / IEC / JIS) (Max. output: 3 mW Peak emission wavelength: 655 nm 0.026 mil)	Red semiconductor laser, Class 1 (FDA / IEC / JIS) (Max. output: 1 mW Peak emission wavelength: 655 nm 0.026 mil)	Red semiconductor laser, Class 2 (FDA / IEC / JIS) (Max. output: 3 mW Peak emission wavelength: 655 nm 0.026 mil)	Red semiconductor laser, Class 1 (FDA / IEC / JIS) (Max. output: 1 mW Peak emission wavelength: 655 nm 0.026 mil)	Red semiconductor laser, Class 2 (FDA / IEC / JIS) (Max. output: 3 mW Peak emission wavelength: 655 nm 0.026 mil)	Red semiconductor laser, Class 1 (FDA / IEC / JIS) (Max. output: 1 mW Peak emission wavelength: 655 nm 0.026 mil)	Red semiconductor laser, Class 2 (FDA / IEC / JIS) (Max. output: 3 mW Peak emission wavelength: 655 nm 0.026 mil)
Material			Enclosure: PBT (Polybutylene terephthalate)(Mounting part: PEI), Lens cover: Acrylic					
Cable			0.1 mm ² , single core two parallel shielded cables, 2 m 6.562 ft long (Connector for amplifier attached)(Note 5)					
Weight			Net weight: 30 g approx. Gross weight: 40 g approx.	Net weight: 30 g approx. Gross weight: 45 g approx.		Net weight: 30 g approx. Gross weight: 40 g approx.		Net weight: 35 g approx. Gross weight: 45 g approx.
Accessories			RF-230 (Reflector): 1 pc. Warning label: 1 set (Labels are written in Japanese, English and Chinese for compliance with various standards.)	RF-330 (Reflector): 1 pc. Warning label: 1 set (Labels are written in Japanese, English and Chinese for compliance with various standards.)	RF-330 (Reflector): 1 pc. Explanation label: 1 set (Labels are written in Japanese and Chinese for compliance with various standards.)	Warning label: 1 set (Labels are written in Japanese, English and Chinese for compliance with various standards.)	Explanation label: 1 set (Labels are written in Japanese and Chinese for compliance with various standards.)	LS-MR1 (Lens attachment) (for line reflective): 1 pc. Warning label: 1 set (Labels are written in Japanese, English and Chinese for compliance with various standards.)

- Notes: 1) Measurement conditions that are not specified are at an ambient temperature of + 23 °C + 73.4 °F.
 2) This product complies with 21 CFR 1040.10 and 1040.11 Laser Notice No. 50, dated July 26, 2001, issued by CDRH (Center for Devices and Radiological Health) under the FDA (Food and Drug Administration). For details, refer to the Laser Notice No. 50.
 3) **LS-H22(F)** is the set model No. for **LS-H21(F)** long sensing range spot reflective type sensor head combined with the **LS-MR1** lens attachment for line reflective type, hence **LS-H21(F)** appears on the sensor head itself.
 4) The sensing range is the value for the **RF-330** [**RF-230** for the **LS-H92(F)**] reflector. In addition, the sensing range is the possible setting range for the reflector. The sensor can detect an object less than 0.1 m 0.328 ft [**LS-H92(F)**: 0.2 m 0.656 ft] away. Note that if there are white papers or specular objects near the sensor head, reflected light from these objects may be received. In such cases, use the M.G.S. function of the amplifier unit to change the response time or incident light sensitivity.
 5) Cable cannot be extended.

SPECIFICATIONS

Amplifiers

Item	Model No.	Type	Connector type	Cable type
		NPN output	LS-401	LS-401-C2
		PNP output	LS-401P	LS-401P-C2
Supply voltage	12 to 24 V DC \pm 10 % Ripple P-P 10 % or less			
Power consumption	Normal operation: 950 mW or less (Current consumption 40 mA or less at 24 V supply voltage) ECO mode: 780 mW or less (Current consumption 33 mA or less at 24 V supply voltage)			
Output (Output 1, Output 2)	<NPN output type> NPN open-collector transistor		<PNP output type> PNP open-collector transistor	
	<ul style="list-style-type: none"> • Maximum sink current: 100 mA (Note 2) • Applied voltage: 30 V DC or less (between output and 0 V) • Residual voltage: 1.5 V or less [at 100 mA (Note 2) sink current] 		<ul style="list-style-type: none"> • Maximum source current: 100 mA (Note 2) • Applied voltage: 30 V DC or less (between output and + V) • Residual voltage: 1.5 V or less [at 100 mA (Note 2) source current] 	
	Output operation	Selectable either Light-ON or Dark-ON, with jog switch		
	Short-circuit protection	Incorporated		
Response time	80 μ s or less (H-SP), 150 μ s or less (FAST), 500 μ s or less (STD), 4 ms or less (U-LG) selectable with jog switch			
External input (Laser emission halt / Full-auto teaching / Limit teaching)	_____		<NPN output type> NPN non-contact input <ul style="list-style-type: none"> • Signal condition High: + 5 V to + V DC or open, Low: 0 to + 2 V DC (source current 0.5 mA or less) • Input impedance: 10 kΩ approx. <PNP output type> PNP non-contact input <ul style="list-style-type: none"> • Signal condition High: + 4 V to + V DC (sink current 3 mA or less), Low: 0 to + 0.6 V DC or open • Input impedance: 10 kΩ approx. 	
Operation indicator	Orange LED (lights up when output 1 and output 2 are ON)			
Laser emission indicator	Green LED (lights up during laser emission)			
Select indicator	Yellow LED (lights up when either output 1 or output 2 is selected)			
MODE indicator	RUN: Green LED, TEACH · L/D ON · TIMER · CUST · PRO: Yellow LED			
Digital display	4 digit (green) + 4 digit (red) LED display			
Sensitivity setting	Normal mode: 2-level teaching / Limit teaching / Full auto teaching / Manual adjustment Window comparator mode: Teaching (1-level, 2-level, 3-level) / Manual adjustment Hysteresis mode: Teaching (1-level, 2-level, 3-level) / Manual adjustment Differential mode: 5-level settings			
Fine sensitivity adjustment function	Incorporated			
Timer function	Incorporated with variable ON-delay / OFF-delay / ONE SHOT timer, switchable either effective or ineffective. (Timer period: 1 ms to 9,999 ms approx.)			
Automatic interference prevention function	Incorporated [Up to four sets of sensor heads can be mounted close together (However, disabled when in H-SP mode)]			
Environmental resistance	Ambient temperature	- 10 to + 55 °C + 14 to + 131 °F (If 4 to 7 units are mounted close together: - 10 to + 50 °C + 14 to + 122 °F, if 8 to 16 units are mounted close together: - 10 to + 45 °C + 14 to + 113 °F)(No dew condensation or icing allowed), Storage: - 20 to + 70 °C - 4 to + 158 °C		
	Ambient humidity	35 to 85 % RH, Storage: 35 to 85 % RH		
	Voltage withstandability	1,000 V AC for one min. between all supply terminals connected together and enclosure		
	Insulation resistance	20 M Ω , or more, with 250 V DC megger between all supply terminals connected together and enclosure		
	Vibration resistance	10 to 150 Hz frequency, 0.75 mm 0.030 in amplitude in X, Y and Z directions for two hours each		
	Shock resistance	98 m/s ² acceleration (10 G approx.) in X, Y and Z directions for five times each		
Material	Enclosure: Heat-resistant ABS, Transparent cover: Polycarbonate, Push button switch: Acrylic, Jog switch: ABS			
Cable	_____ (Note 3)	0.15 mm ² 5-core cabtyre cable, 2 m 6.562 ft long		
Cable extension	Extension up to total 100 m 328.084 ft is possible with 0.3 mm ² , or more, cable.			
Weight	Net weight: 15 g approx., Gross weight: 20 g approx.		Net weight: 65 g approx., Gross weight: 75 g approx.	

Notes: 1) Measurement conditions that are not specified are at an ambient temperature of + 23 °C + 73.4 °F.
 2) 50 mA if 5 to 8 connector type amplifiers are connected in cascade, and 25 mA if 9 to 16 connector type amplifiers are connected in cascade.
 3) The cable is not supplied as an accessory for connector type LS-401(P). Be sure to use the optional quick-connection cables given below.
 Main cable (4-core): CN-74-C1 (cable length 1 m 3.281 ft), CN-74-C2 (cable length 2 m 6.562 ft), CN-74-C5 (cable length 5 m 16.404 ft)
 Sub cable (2-core): CN-72-C1 (cable length 1 m 3.281 ft), CN-72-C2 (cable length 2 m 6.562 ft), CN-72-C5 (cable length 5 m 16.404 ft)

I/O CIRCUIT AND WIRING DIAGRAMS

NPN output type

I/O circuit diagram

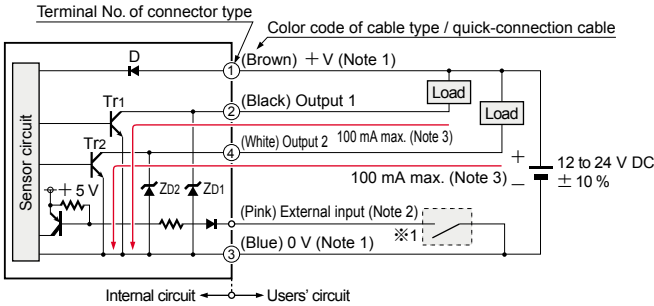

Notes: 1) The quick-connection sub cable does not have +V (brown) and 0 V (blue).
The power is supplied from the connector of the main cable.
2) Connector type **LS-401(P)** does not incorporate the external input.
3) 50 mA max. if 5 to 8 connector type amplifiers are connected in cascade, and 25 mA max. if 9 to 16 connector type amplifiers are connected in cascade.

※1

Non-voltage contact or NPN open-collector transistor

- External input
- High: +5 V to +V, or open
- Low: 0 to +2 V (source current: 0.5 mA or less)
- Light emission halts and teaching occurs when at Low.

Symbols ... D: Reverse supply polarity protection diode
Zd1, Zd2: Surge absorption zener diode
Tr1, Tr2 : NPN output transistor

Wiring diagram

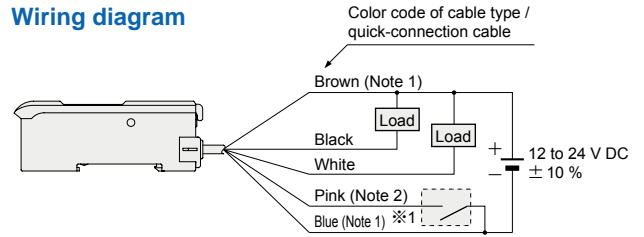

Notes: 1) The quick-connection sub cable does not have brown lead wire and blue lead wire.
The power is supplied from the connector of the main cable.
2) The quick-connection cable does not have a pink lead wire.

Terminal layout of connector type

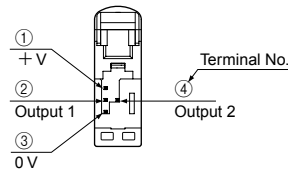

※Connector for amplifier (CN-EP1) pin position

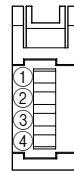

Terminal No.	Connection cable	
①	Conductor core wire: Brown	Cable color: Gray
②	Shield wire	
③	Conductor core wire: Yellow	Cable color: Black
④	Shield wire	

PNP output type

I/O circuit diagram

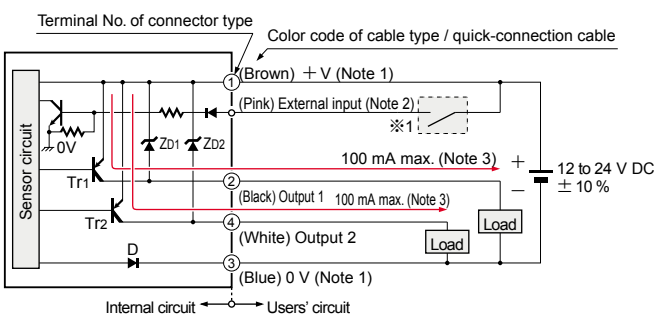

Notes: 1) The quick-connection sub cable does not have +V (brown) and 0 V (blue).
The power is supplied from the connector of the main cable.
2) Connector type **LS-401(P)** does not incorporate the external input.
3) 50 mA max. if 5 to 8 connector type amplifiers are connected in cascade, and 25 mA max. if 9 to 16 connector type amplifiers are connected in cascade.

※1

Non-voltage contact or PNP open-collector transistor

- External input
- High: +4 V to +V (sink current: 3 mA or less)
- Low: 0 to +0.6 V, or open
- Light emission halts and teaching occurs when at Low.

Symbols ... D: Reverse supply polarity protection diode
Zd1, Zd2: Surge absorption zener diode
Tr1, Tr2 : PNP output transistor

Wiring diagram

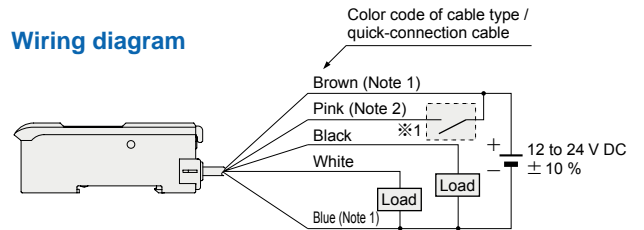

Notes: 1) The quick-connection sub cable does not have brown lead wire and blue lead wire.
The power is supplied from the connector of the main cable.
2) The quick-connection cable does not have a pink lead wire.

Terminal layout of connector type

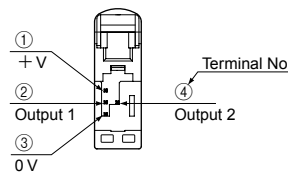

※Connector for amplifier (CN-EP1) pin position

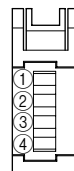

Terminal No.	Connection cable	
①	Conductor core wire: Brown	Cable color: Gray
②	Shield wire	
③	Conductor core wire: Yellow	Cable color: Black
④	Shield wire	

PRECAUTIONS FOR PROPER USE

• This catalog is a guide to select a suitable product. Be sure to read the instruction manual attached to the product prior to its use.



• Never use this product as a sensing device for personnel protection.
 • In case of using sensing devices for personnel protection, use products which meet regulations and standards, such as OSHA, ANSI or IEC etc., for personnel protection applicable in each region or country.

Cautions for laser beams



• These products are class 2 (LS-H□-A: Class 1) laser in compliance with JIS / IEC / FDA / GB standards. To reduce the risk of danger, do not look directly at the laser beam or view it through an optical system.
 • A label with instructions as found at the below is affixed to the product. Handle this sensor as per the instruction on the labels.

JIS / IEC / GB Class 2 type



FDA Class 1 type



(This product has warning labels attached and included in the packaging that are written in Japanese, English and Chinese for compliance with various standards.)

(This product has explanation labels attached and included in the packaging that are written in Japanese, English and Chinese for compliance with various standards.)

• The safety standard IEC 60825-1-2001 specifies the use of laser beam products. Please read it carefully before using the laser beam sensor.

Part description (Amplifier)

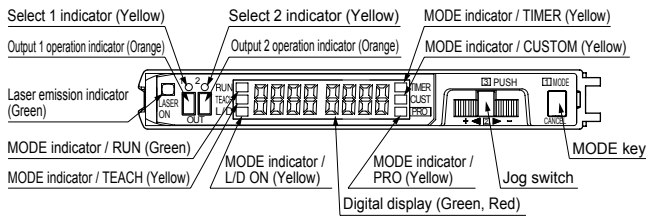

Spot-shape adjuster (Only for LS-H21□, LS-H22□)

• The diffuse reflective type LS-H21□ and LS-H22□ incorporate the spot-shape adjuster to adjust the shape of spots.

Spot-shape adjuster	Description
	Turn the spot-shape adjuster clockwise or counter-clockwise to adjust the spot shape at your desired detecting distance. However, if the adjuster is turned too far, it may be damaged.

Mounting

Amplifier

<How to mount the amplifier>

- Fit the rear part of the mounting section of the amplifier on a 35 mm 1.378 in width DIN rail.
- Press down the rear part of the mounting section of the unit on the 35 mm 1.378 in width DIN rail and fit the front part of the mounting section to the DIN rail.

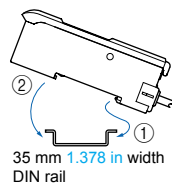

<How to remove the amplifier>

- Push the amplifier forward.
- Lift up the front part of the amplifier to remove it.

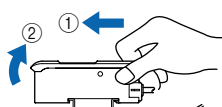

Note: Be careful. If the front part is lifted without pushing the amplifier forward, the hook on the rear portion of the mounting section is likely to break.

<How to mount the sensor head>

- Insert the sensor head connector into the inlet until it clicks.
- Fit the cover to the connector.

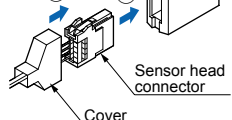

Sensor head

• The tightening torque should be 0.5 N·m or less.

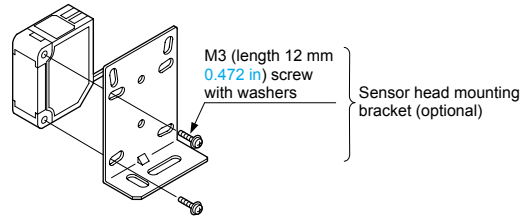

• When placing the sensor head horizontally or vertically, the reflector must also be positioned horizontally or vertically as shown in Fig. 1 below.
 If the sensor head is placed horizontally or vertically but the reflector is leaned as shown in Fig. 2 below, the reflection amount will decrease, which may cause unstable detection.

Fig. 1 Proper positioning

When placing the sensor head horizontally or vertically, the reflector shall also be positioned horizontally or vertically.

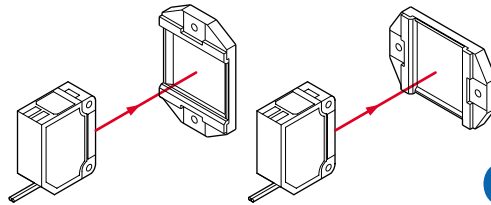

Good

Fig. 2 Improper positioning

When placing the sensor head horizontally or vertically, but the reflector is leaned.

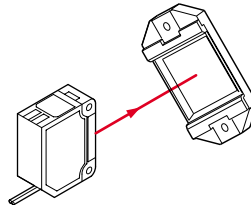

Not good

Lens attachment for line reflective type (LS-MR1)

• The lens attachment for line reflective type LS-MR1 mounted in the long sensing range line reflective type LS-H22□ is removable. When LS-H22□ is used without LS-MR1, it will provide the equivalent performance to the long sensing range spot reflective type LS-H21□. In addition, the optional LS-MR1 can be attached to LS-H21□ to obtain the performance equivalent to LS-H22□.
 • Keep the lens clean of dust, dirt, water, oil, grease, etc.
 • Do not apply any excessive force to LS-MR1. Such force may cause damage.

Removing method

- Insert a screwdriver into the fixing slot located at the top of sensor head.
- Tilt the screwdriver inserted in Step ① to remove LS-MR1.

Mounting method

- The size of upper fixing hook of LS-MR1 is not same as the lower fixing hook. After identifying the upper and lower fixing hooks, insert LS-MR1 upper fixing hook into the fixing slot at the top of sensor head and then insert LS-MR1 lower fixing hook into the fixing slot at the bottom of sensor head.
- After mounting, check that LS-MR1 is properly fixed to the sensor head.

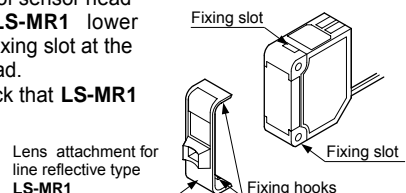

PRECAUTIONS FOR PROPER USE

Wiring

- Make sure that the power supply is off while wiring.
- Verify that the supply voltage variation is within the rating.
- Take care that if a voltage exceeding the rated range is applied, or if an AC power supply is directly connected, the sensor may get burnt or damaged.
- If power is supplied from a commercial switching regulator, ensure that the frame ground (F.G.) terminal of the power supply is connected to an actual ground.
- In case noise generating equipment (switching regulator, inverter motor, etc.) is used in the vicinity of this product, connect the frame ground (F.G.) terminal of the equipment to an actual ground.
- Take care that short-circuit or wrong wiring of the load may burn or damage the sensor.
- Do not run the wires together with high-voltage lines or power lines or put them in the same raceway. This can cause malfunction due to induction.
- Ensure that an isolation transformer is utilized for the DC power supply. If an auto transformer is utilized, the main amplifier or power supply may be damaged.
- Make sure to use the optional quick-connection cable for the connection of the amplifier [connector type **LS-401(P)**]. Extension up to total 100 m (328.084 ft) is possible with 0.3 mm², or more, cable. However, in order to reduce noise, make the wiring as short as possible.

Others

- Do not use during the initial transient time (0.5 sec. approx.) after the power supply is switched on.
- Because the sensitivity is higher in U-LG mode than in other modes, it can be more easily affected by extraneous noise. Check the operating environment before use.
- This sensor is suitable for indoor use only.
- Avoid dust, dirt, and steam.
- Take care that the product does not come in direct contact with water, oil, grease, or organic solvents, such as, thinner, etc.
- This sensor cannot be used in an environment containing inflammable or explosive gasses.
- Never disassemble or modify the sensor.

DIMENSIONS (Unit: mm in) The CAD data in the dimensions can be downloaded from the SUNX website: <http://www.sunx.co.jp/>

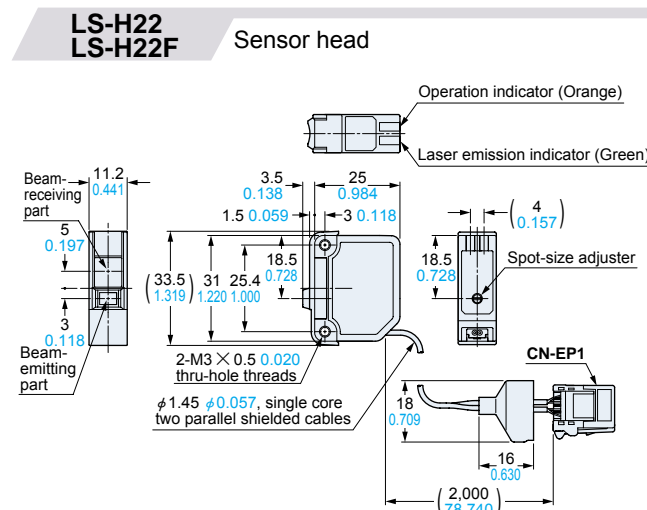
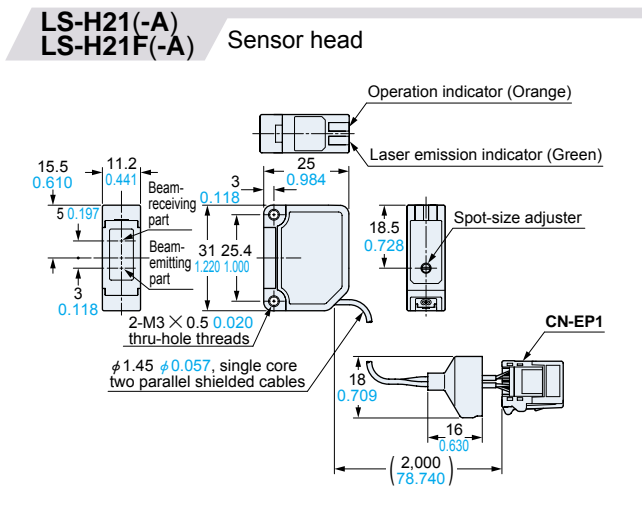
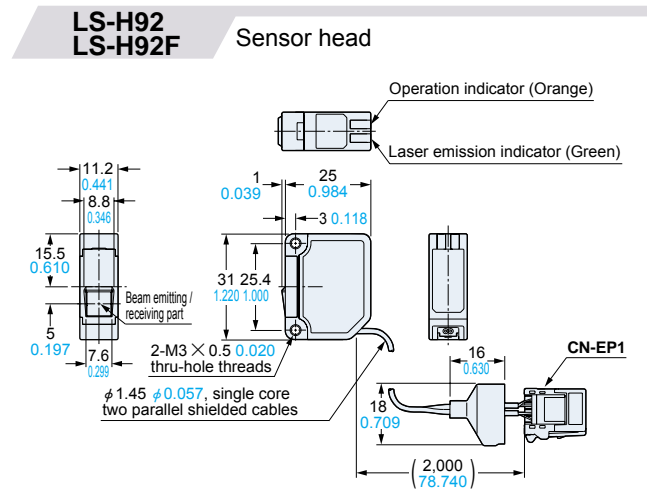
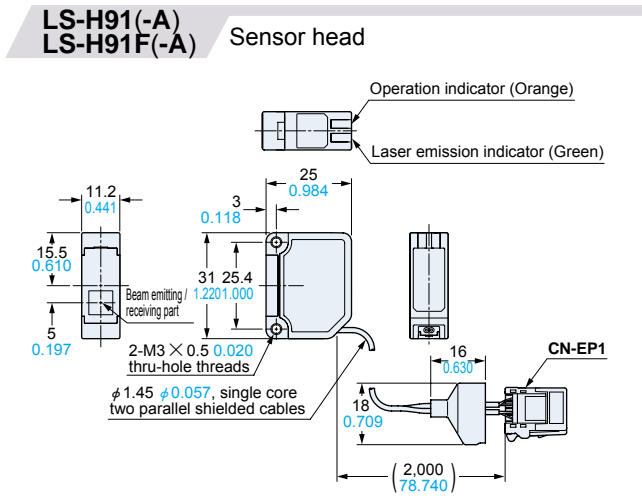

DIMENSIONS (Unit: mm in) The CAD data in the dimensions can be downloaded from the SUNX website: <http://www.sunx.co.jp/>

**LS-401
LS-401P** Amplifier

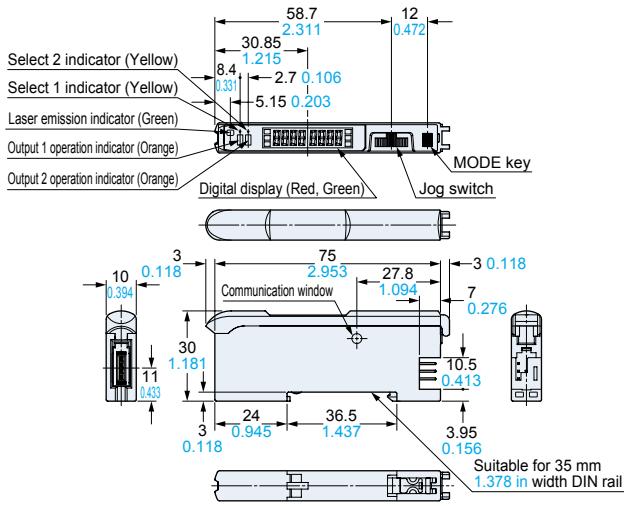

**LS-401-C2
LS-401P-C2** Amplifier

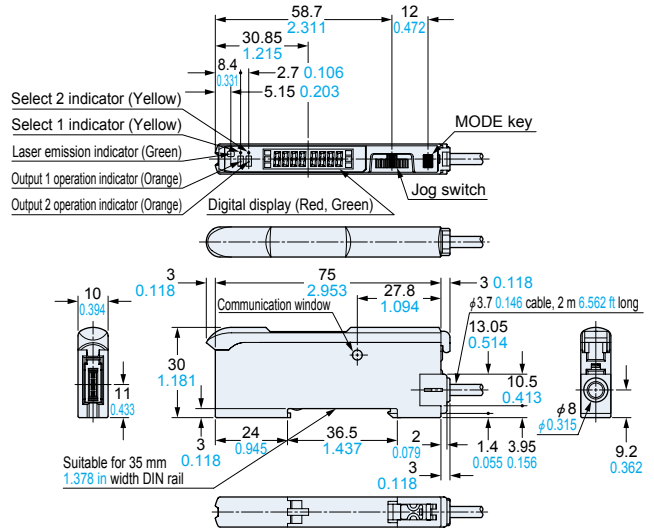

**CN-74-C1 CN-74-C2
CN-74-C5** Main cable (Optional)

• Length (L)

Model No.	Length (mm in)
CN-74-C1	1,000 39.370
CN-74-C2	2,000 78.740
CN-74-C5	5,000 196.850

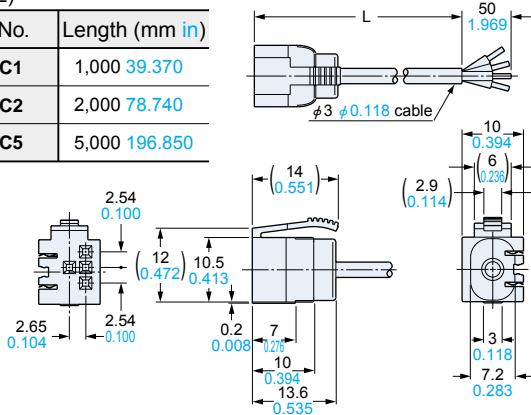

**CN-72-C1 CN-72-C2
CN-72-C5** Sub cable (Optional)

• Length (L)

Model No.	Length (mm in)
CN-72-C1	1,000 39.370
CN-72-C2	2,000 78.740
CN-72-C5	5,000 196.850

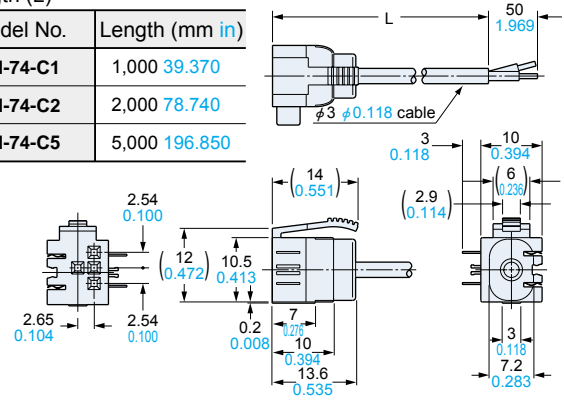

MS-DIN-E End plate (Optional)

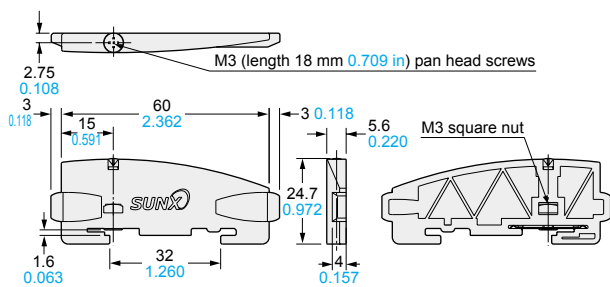

Material: Polycarbonate

RF-230 Reflector [Accessory for LS-H92(F)]

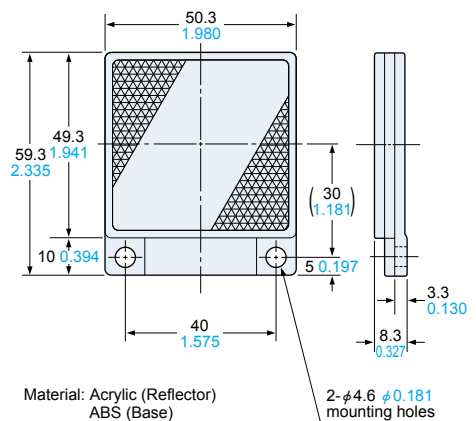

Material: Acrylic (Reflector)
ABS (Base)

2- ϕ 4.6 ϕ 0.181
mounting holes

DIMENSIONS (Unit: mm in) The CAD data in the dimensions can be downloaded from the SUNX website: <http://www.sunx.co.jp/>

RF-330 Reflector (Accessory for LS-H91□)

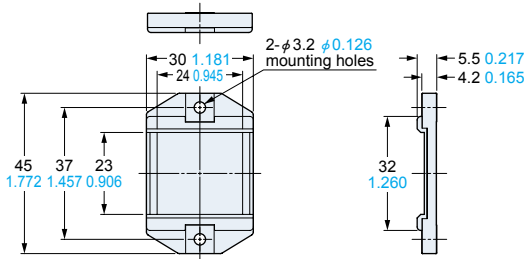

Material: Acrylic (Reflector)
ABS (Base)

RF-310 Reflector (Optional)

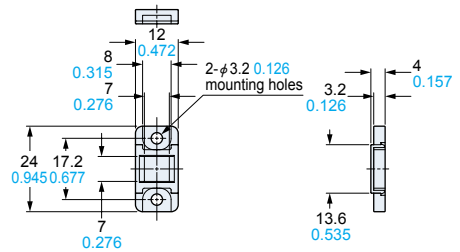

Material: Acrylic (Reflector)
ABS (Base)

RF-33
RF-31 Reflective tape (Optional)

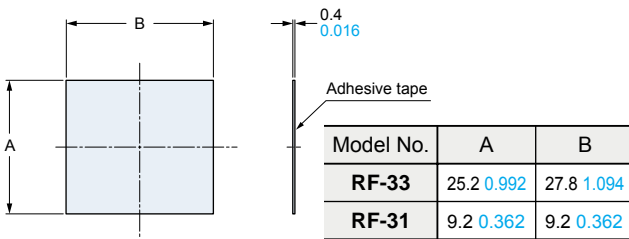

MS-DIN-2 Amplifier mounting bracket (Optional)

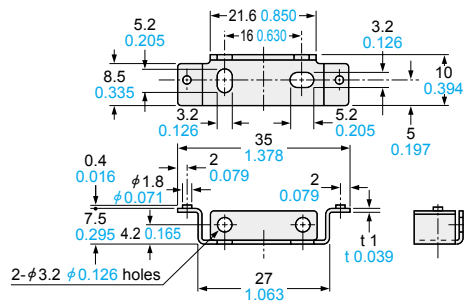

Material: Cold rolled carbon steel (SPCC)
(Uni-chrome plated)

MS-CX-1 Sensor head mounting bracket (Optional)

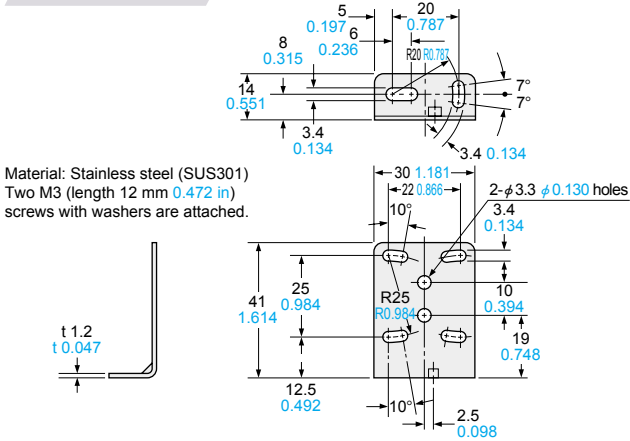

Material: Stainless steel (SUS301)
Two M3 (length 12 mm 0.472 in)
screws with washers are attached.

MS-CX-2 Sensor head mounting bracket (Optional)

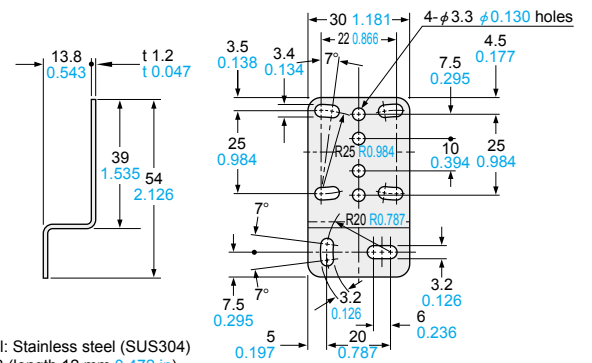

Material: Stainless steel (SUS304)
Two M3 (length 12 mm 0.472 in)
screws with washers are attached.

MS-CX-3 Sensor head mounting bracket (Optional)

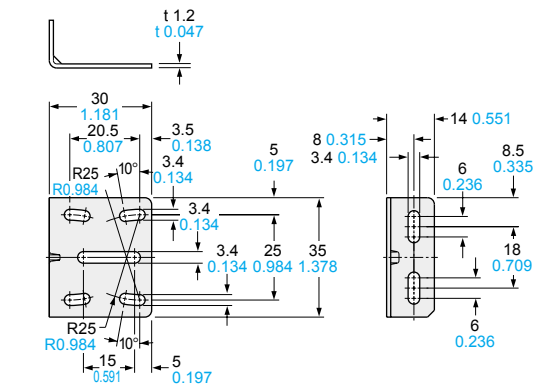

Material: Stainless steel (SUS304)
Two M3 (length 12 mm 0.472 in)
screws with washers are attached.

MS-CX-4 Sensor head mounting bracket (Optional)

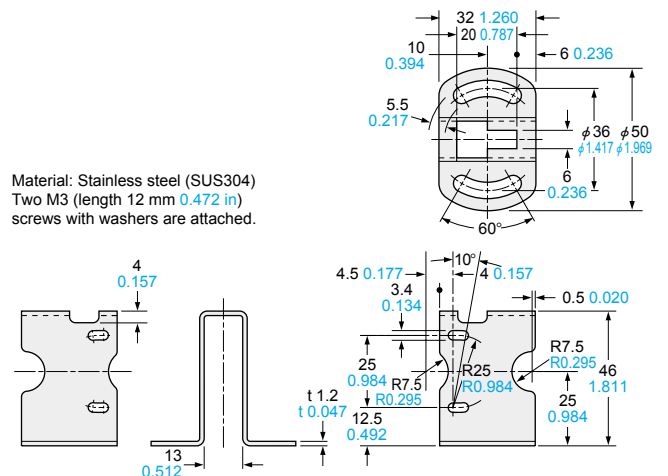

Material: Stainless steel (SUS304)
Two M3 (length 12 mm 0.472 in)
screws with washers are attached.

MS-RF23 Reflector mounting bracket for RF-230 (Optional)

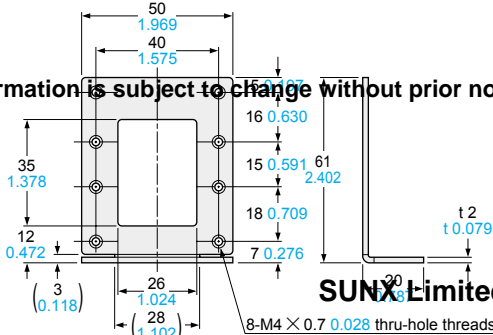
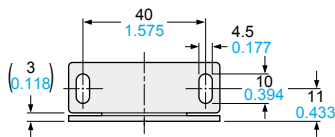

All information is subject to change without prior notice.

SUNX Limited

Material: Cold rolled carbon steel (SPCC)
(Uni-chrome plated)

Two M4 (length 10 mm 0.394 in) screws with washers are attached.

8-33-7211
FAX: +81-(0)

Overseas Sales Dept.

Phone: +81-(0)568-33-7861
FAX: +81-(0)568-33-8591

Assembly dimensions

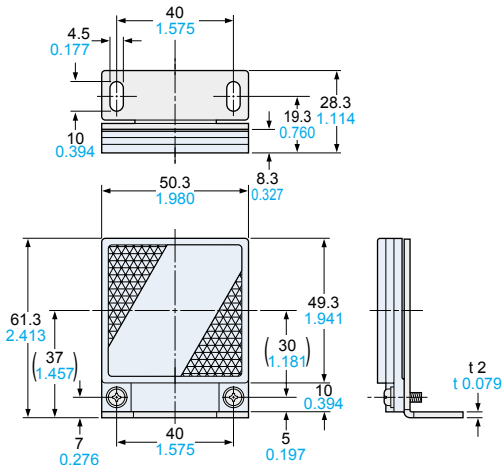

Trask Instrumentation Inc.
POB 1778
Greer, SC 29652
Ph: 864-848-3993
mike@traskinst.com
www.traskinstrumentation.com